

Insulated panels for external roof and wall cladding



A guide to fire safety and performance in fire

Foreword

Insulated panels are used extensively for the external roof and wall cladding of buildings in most construction sectors. They are selected for their thermal and energy saving properties and their construction and installation benefits. Insulated panels are single piece factory engineered units comprising two metal faces and a fully insulating core.

Over the past 15 years the performance in fire of insulated panels has been analysed in depth. In particular studies have highlighted the differences in design, materials and method of fixing between external roof and wall panels and other sandwich type panels designed specifically for internal applications.

In addition, since 2004 only fully certificated panels to Insurance Industry tested standards have been manufactured in the UK resulting in a further improvement in their performance in fire.

The Guide has been prepared to provide comprehensive information on the fire safety and performance in fire of external roof and wall panels. External roof and wall panels are uniquely designed for the external envelope and are securely fixed to the main building structure. They perform totally differently in fire compared to free standing internal systems. This is borne out by large scale tests and real fire scenarios.

Studies have also shown that rarely have external roof and wall panels been involved in the initial stages of a fire, only becoming involved as a result of a fully developed fire.

European fire classifications

UK Classifications for reaction to fire; fire resistance; and external performance (roofs) based on European harmonised fire tests were agreed in 2001 and now run concurrently with the original UK BS 476 classifications. Both classifications are referred to in this Guide for ease of comparison and reference.

New thermal performance requirements

In addition to the requirements for fire performance, specifiers and designers must also take into account the new thermal performance and airtightness regulations for the external roof and wall systems of buildings [Amendment to Building Regulations: Approved Document L2: 2010 [1]]; and in Building [Scotland] Regulations – Technical Handbook 2010: Section 6 Energy.

The Case Studies in Section 11 of this Guide illustrate that the engineered junction details, which have been designed to meet the Energy Conservation Regulations, have also benefited the fire performance of Insulated Panels and can readily be used to support good fire engineering practice.

The EPIC Fire Guide 2011

The EPIC Fire Guide 2011 updates the original 2002 Fire Guide and for the first time links the performance of Insulated Panels in actual fires with the indicated performance of the large scale Insurance Industry tests.

The guide is divided into two parts.

Part 1

Sections 1 to 4 review the development of insulated panels; their performance in fire; and the regulatory requirements for external cladding and roofing in England, Wales and Northern Ireland and also in Scotland.

Sections 5 and 6 cover the specific requirements governing fire safety in hospitals and schools. In sections 7 and 8 additional fire precautions that may be desirable to minimise property damage and business interruption are also covered together with an overview of fire safety engineering techniques and how they may be applied to assess the impact of materials used in the external building envelope.

Part 2

Sections 10 to 12 describe the tests required to meet regulatory and insurance requirements. The Insurance Industry large scale tests in particular are then linked to the fire research findings and the evidence of actual fire case histories to illustrate how indicative these tests can be in determining fire performance, particularly during the developing stages of a fire.

Appendix

An additional Appendix provides guidance on the fire safety procedures that are appropriate where construction work is involved or is carried out in the proximity of insulated panels. A substantial number of major fires can be attributed to the poor management of fire safety both during construction and maintenance operations and as part of the day-to-day operation of the building. This Appendix refers equally to all forms of roof and wall cladding and not specifically to insulated panels.

Download EPIC information from the website

This guide to Fire safety and performance in fire together with other guides, can readily be downloaded from the EPIC website at www.epic.uk.com

Contents

Part 1: General information and regulatory requirements

Section 1	Introduction	3
	The history of Insulated Panels and their performance in fire	
Section 2	Statutory requirements	7
	The various statutory requirements applicable through the United Kingdom in which legislation is principally concerned with fire	
Section 3	Building regulations for England, Wales and Northern Ireland	9
	A summary of the requirements of the Building Regulations 2010 in England and Wales that are relevant to roof and wall insulated panel systems	
Section 4	Building standards – Scotland	19
	A summary of the requirements of the Building Standards (Scotland) Regulations 2004 that are relevant to roof and wall insulated panel systems	
Section 5	Fire precautions in hospitals	26
	Guidance on the design for fire safety in hospitals as given in the NHS Firecode documents Health Technical Memorandum, Guidance HTM 05 02	
Section 6	Fire precautions in schools	29
	Guidance on the design for fire safety in schools as given in the design guide Building Bulletin 100 (BB100)	
Section 7	Business and property protection	31
	Additional fire precautions that may be desirable to minimize property damage and business interruption	
Section 8	Fire safety engineering	35
	An overview of fire safety engineering techniques and how they may be applied to assess the impact of materials used in the external building envelope	

Part 2: Understanding how insulated panels react in fire

Section 9	Regulatory tests	41
	Summary and commentary on the tests to meet regulatory requirements	
Section 10	Large scale tests	42
	Summary and commentary on the large scale insurance industry tests required to meet Insurance Industry requirements	
Section 11	Fire research and fire case studies	44
	Review of research studies into major fires including case studies of both internally and externally originated fires	

Appendix: Management of fire safety

This appendix applies equally to all forms of roof and wall cladding and not specifically to insulated panels. It covers the management of fire safety both during construction and maintenance operations and as part of the day-to-day operation of the building

PART I

General information and regulatory requirements

Sections 1 to 4 review the development of insulated panels; their performance in fire; and the regulatory requirements for external cladding and roofing in England, Wales and Northern Ireland and also in Scotland.

Sections 5 and 6 cover the specific requirements governing fire safety in hospitals and schools. In sections 7 and 8 additional fire precautions that may be desirable to minimise property damage and business interruption are also covered together with an overview of fire safety engineering techniques and how they may be applied to assess the impact of materials used in the external building envelope.

General information and regulatory requirements

Introduction

This guide is designed to give a clear understanding of how insulated panels work as the external envelope of a modern building by combining the requirements for fire performance with the experience and findings gained through fire tests and from the study of actual fires.

1.1 Insulated panels

The guide covers the requirements for and fire performance of insulating panels used to clad the roofs and external walls of buildings. These have variously been called sandwich panels, composite panels, insulated panels, factory-engineered panels etc. The term Insulated Panel has been used throughout the guide as their primary function is as an energy saving construction element.

Nevertheless, it is the 'sandwich nature', in which two metal facings are bonded either side of a core insulating material, which gives the panels their excellent strength and mechanical properties and improves their fire performance.

1.2 External cladding

The term 'external' is emphasised throughout. This is to clearly separate external and internal systems and applications. Lack of differentiation between the two distinct types of panel has led to some confusion regarding the very different performance in practice, particularly their fire performance.

External insulated panels have been specifically designed to fabricate the external envelope of buildings. They are required to absorb the considerable forces – wind, snow, static loads etc – to which the roofs and walls of buildings are subject and to transmit those forces to the supporting structure. They are also required to be weather tight and control energy loss through air tightness at the joints. As a result the method of fixing needs to be strong and the joint design robust and effective.

Internal sandwich panels on the other hand are generally structurally weaker systems designed for ease of installation/demountability and often to satisfy the thermal insulation and hygiene demands of the cold store and food processing industries. In the past there have been a number of high profile fires involving this internal type of system and the potential weaknesses and corrective design solutions are well documented. It should be noted that correctly designed solutions using panels with PIR cores in current cold store applications have been fully tested and provide an acceptable level of fire performance.

1.3 History of Insulated Panel Systems

Insulated panels have been used as the external roof and walls of buildings in increasing volumes since the early 1980's although their history in use dates back to the late 1960's. They are now the most used cladding system for a wide range of commercial and industrial buildings.

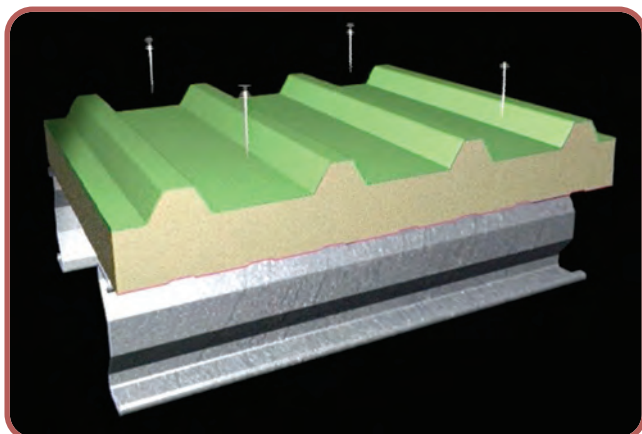

Insulated panels are factory engineered and produced one-piece cladding panels consisting of two metal faces positioned either side of an insulating core, which completely fills the space between. The facings are fully bonded to the core so that the panel acts compositely when under load. [Fig. 1].

Figure 1. Factory engineered insulation panels

Facings used for insulated panels are predominantly of steel although aluminium can also be used for specific applications. The insulating core is bonded to the facings either auto-adhesively (urethanes) or by a conventional adhesive bond (mineral wool and polystyrene). Initially all external panels were manufactured with PUR (polyurethane) rigid urethane insulation cores whereas internal panels, following a separate parallel development, used polystyrene [PS]. The thickness of external panels at this time was 25-30mm compared to the 80-100mm typical of current rigid urethane cored production.

Since 2004 all rigid urethane insulation cored panels manufactured in the UK have used PIR (polyisocyanurate) in formulations certificated by the Loss Prevention Certification Board (LPCB) and FM Global in their dedicated large scale fire tests (see Section 10). Certificated PIR Insulated Panels account for over 90% of insulated panels used externally.

Mineral wool cored wall panels were introduced in the 1990's for applications where enhanced fire performance was required. MW panels account for about 8% of the external insulated panel market.

Other core materials (polystyrene, phenolic foam and cellular glass) have been used from time to time in the production of insulated panels but their use has largely been restricted to internal applications. Polystyrene (PS) has been incorporated in some architectural wall panels but volumes with this insulation are very low. Certificated PIR and MW panels have now replaced PS for all internal panel applications.

1.4 History of fire performance of Insulated Panels

Insulated panels, the majority with rigid urethane cores, have been used for over 30 years with an exemplary record (in fire terms) as the external roof and wall cladding of buildings.

Analysis of the collated information from major fires in which Insulated Panels have been involved and subsequent regular monitoring (see Section 10) indicates:

There are no recorded incidents where external insulated panels have caused or have been involved in the initial stages of a fire.

External roof and wall insulated panels have only become involved when an already established internal fire has reached a fully developed stage;

- During the development stage any involvement of the fire load from external insulated panels is gradual and does not provide an immediate and total contribution to the fire development
- There is no flaming or burning within PIR cored Insulated Panels
- Due to the method of external fixing and engineered joint designs, insulated panels forming the external envelope retain their structural integrity until the structural support is compromised or fails
- Similar fire performance is observed when Insulated Panels are subject to an external flame attack

Fire tests and fire case studies have shown that certificated PIR cores further improve the fire performance of Insulated Panels with the result that engineered insulated panel systems with certificated PIR or MW cores and designed for the external envelopes of buildings are no longer regarded as a concern in fires.

For further information on the performance in fire of external insulated panels see sections 10-11.

General information and regulatory requirements

Introduction

1.5 Specification

Buildings are becoming increasingly complex. The range of materials and components are more extensive, with greater opportunity for architectural expression using modern materials such as insulated panels. Latest designs often require a greater degree of flexibility to accommodate change of layout, information technology, product and system changes etc. Speed of installation is of particular importance in many applications.

Insulated panels and systems need to satisfy a variety of factors including speed of construction, cost, ease of installation as well as meeting the new energy efficiency regulations and other technical requirements including fire.

The building designer is faced with a number of specification considerations encompassing a wide range of practical, commercial, technical and aesthetic factors of which fire is but one. These choices can be classified under the headings of 'regulatory' or 'general design/construction'.

The weightings given to different design issues will be influenced by many factors and will vary according to statutory requirements and the objectives of the client and the designer. Most of the specification choices directly influence cost, construction speed, and the cost in life/energy performance of the building.

Fire safety and fire performance may be subject to regulatory requirements. Generally the current range of commercially available insulated panels with PIR or MWV cores, when correctly designed and installed, should meet the present building regulations requirements [Section 2].

Insulated panels are suitable for a wide range of building applications. However like all cladding systems rarely will a single product provide the best performance for all design requirements and it is necessary to consider the optimum balance of properties for the particular building. In fire safety terms a cladding system that is more than adequate for a typical single storey storage building may be unsuitable for a high rise hospital where evacuation is impractical and staff and patients will need to remain in the building during a fire.

Specification factors for insulated panels used for external roof and wall cladding.

Energy: Regulatory requirement –

Building Regulations –

Approved Document L2: 2010

~ Energy performance of fabric

[new insulation and air tightness levels]

Weight

Fire: Approved Document B: 2010

Reaction to fire

Fire resistance

[see sections 3 and 4]

Cost

Aesthetics

Buildability

Speed of installation

Durability and life cycle

Acoustics

Environmental

Health and safety

Specific requirements from client; insurance industry etc.

2 General information and regulatory requirements

Statutory Requirements

2.1 Building Regulations

The Building Regulations are the statutory requirements that are most likely to impact on the fire performance specification of external cladding systems.

Building Regulations apply to the design and construction of new buildings and only apply to existing buildings if they are being extended, altered or undergoing a material change of use.

England and Wales, Scotland and Northern Ireland each have their own building regulations and each country has its own set of guidance documents for fire safety. It is important to recognise that the guidance applicable in Scotland can be significantly different to that applicable in England and Wales or Northern Ireland.

The Building Regulations set out high-level objectives in a functional form e.g.:

The building shall be designed and constructed so that there are appropriate provisions for the early warning of fire, and appropriate means of escape in case of fire to a place of safety outside of the building capable of being safely and effectively used at all material times.

The Regulations themselves do not provide guidance on how these objectives may be met and it is necessary to make reference to the supporting guidance documents that are published by the relevant government office.

Table 1. Building Regulations and guidance applicable in the UK

Country	Regulations	Guidance
England & Wales	Building Regulations 2010 [2]	Approved Document B
Scotland	The Building (Scotland) Regulations 2004[3]	Technical Handbook (Section 2 – Fire)
Northern Ireland	The Building Regulations (Northern Ireland) 2001[4]	Technical Booklet E

The recommendations applicable to external cladding in Approved Document B (England & Wales) and Technical Bulletin E (Northern Ireland) are very similar and are summarised in section 3. The recommendations of the Scottish Technical Handbook are summarised in section 4.

2.2 Fire safety legislation

When a building has been completed and is in use the safety of the occupants and those who may be in the vicinity of the building is governed by the following fire safety legislation:

- England and Wales – The Regulatory Reform (Fire safety) Order 2005
- Fire Scotland Act 2005
- The Fire Safety Regulations (Northern Ireland) 2010

Under this fire safety legislation it is a requirement for employers or persons with control, to any extent, of a building to carry out a fire risk assessment. This fire risk assessment should be “suitable and sufficient” and involves identifying and evaluating:

- sources of ignition
- combustible materials
- people at risk
- adequacy of escape routes
- options for risk removal and reduction
- recording of findings
- planning to prevent fire and keep people safe from its effects
- training staff to ensure they know what to do in the event of fire

2 General information and regulatory requirements

Statutory Requirements

Whilst the Building Regulations do not apply retrospectively to existing buildings (unless they are subject to a significant change of use or modification) the fire safety legislation applies equally to new and existing buildings.

In most cases the legislation is enforced by the fire and rescue service, which is empowered to issue prohibition, and improvement notices if the requirements of the legislation are not met. In serious cases failure to comply has resulted in large fines and imprisonment.

There is no bar to the retrospective application of the fire safety legislation to construction materials (e.g. cladding) that complied with the building regulations guidance applicable at the time of construction, but the fire safety legislation is unlikely to require any modification or replacement. However, there may be circumstances where additional fire precautions are appropriate (e.g. to protect exposed insulation material during maintenance or alteration works).

EPIC Guide to Insulated Panels and the Regulatory Reform (Fire Safety) Order 2005

This extensive guide provides information to assist in the preparation of a fire risk assessment for buildings that are constructed with or contain Insulated Panels.

www.epic.uk.com/rrfso.jsp

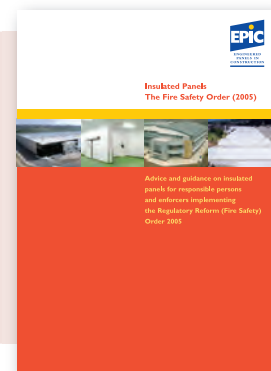

2.3 Construction (Design and Management) Regulations

The Construction (Design and Management) Regulations 2007 (CDM) relate to all aspects of construction and affect all those concerned in the construction process. The CDM regulations impose specific obligations on designers to consider matters relating to safety during construction and subsequent maintenance of the completed building.

The CDM regulations require that any foreseeable risks associated with the construction and the continuing maintenance and operation of a building are identified and effectively managed and controlled. Guidance on appropriate management procedures that are applicable to all types of building systems not just buildings with insulated panels is given in the Appendix.

3 General information and regulatory requirements

Building regulations for England, Wales and Northern Ireland

3.1 Functional requirements

As described in Section 2 the functional requirements of the Building Regulations require that 'reasonable', 'adequate' or 'appropriate' steps are taken to ensure the health and safety of people in and around buildings. These requirements are summarised below.

3.1.1 Escape

Requirement B1 requires that adequate escape routes be provided to enable the occupants to reach a safe location outside of the building. Suitable means of giving warning of a fire are also required.

3.1.2 Fire spread across surfaces

Requirement B2 is intended to ensure that materials used as wall and ceiling linings do not promote rapid fire spread or unduly contribute to the heat produced by a fire.

3.1.3 Building structure

Requirement B3 requires that appropriate measures be taken to ensure that:

- the structural stability of the building will be maintained;
- a wall between two buildings will resist fire spread between the buildings;
- buildings are subdivided into compartments to restrict the size of a fire;
- unseen voids are subdivided to inhibit hidden fire spread.

These objectives are generally achieved by providing fire resisting constructions.

3.1.4 External fire spread

Requirement B4 is primarily intended to prevent the spread of fire from one building to another as a result of heat radiation or airborne burning brands. This is achieved by:

- controlling external surfaces of walls and roofs;
- providing fire resisting external walls when appropriate.

3.1.5 Facilities for the fire service

Requirement B5 requires that reasonable facilities are available to enable fire appliances to gain access to the building and to enable fire fighters to protect life.

3.2 Approved Guidance

Approved Document B (England & Wales) and Technical Note E (Northern Ireland) provide guidance on how the functional requirements of the regulations may be met taking account of the use, occupancy, height (of top storey) and area of the building. Approved Document B and Technical Note E apply to most building types except for hospitals and schools which have their own specific guidance which is summarised in Sections 5 and 6 respectively.

3 General information and regulatory requirements

Building regulations for England, Wales and Northern Ireland

3.3 Recommendations for the external envelope

The main recommendations of the approved guidance that impact on the specification of external cladding systems are summarised in the following sections. The two principle parts that affect the specification and use of insulated panels are:

- B2: Internal fire spread (linings) and
- B4: External fire spread.

3.3.1 B2 Internal fire spread

Performance standards are set to ensure that internal lining materials do not promote rapid flame spread or contribute significantly to the heat released from a fire.

Currently the fire spread performance of materials can either be assessed in accordance with the British Standard test regime (BS 476: Parts 6 & 7 [6 and 7]) or the European classification system (BS EN 13501-1 [8]). The European classification system includes criteria for the assessment of the production of smoke and flaming droplets but these criteria do not form part of the UK classification process.

The recommended performance levels for internal linings to walls and ceilings based on British Standards and European Standards is summarised in table 2. For the majority of buildings, the internal lining should exhibit a Class 1 surface spread of flame (Euroclass C) except where it forms part of a circulation or protected route in which case it should have a Class 0 (Euroclass B) rating.

Table 2. Classification of internal linings in accordance with British and European Standards

Location	British Standards	Euroclass
Internal walls and rooms	I	C
Circulation spaces (corridors, lobbies, stairways)	0	B

3.3.2 B4 External fire spread between buildings

An objective of the Building Regulations is to ensure that fire does not spread from one building to another as a result of heat radiation or airborne burning brands.

Figures 2 and 3 illustrate how radiation and airborne burning brands can spread between buildings.

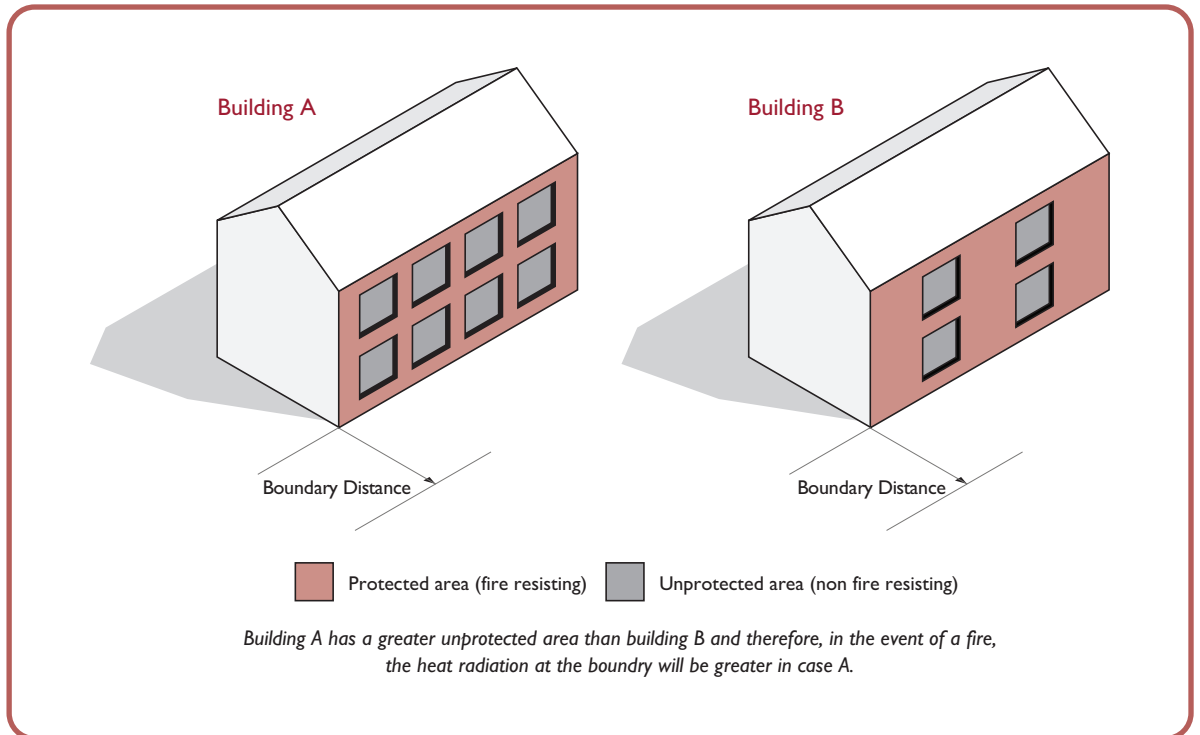

Figure 2. Fire spread between buildings by radiation

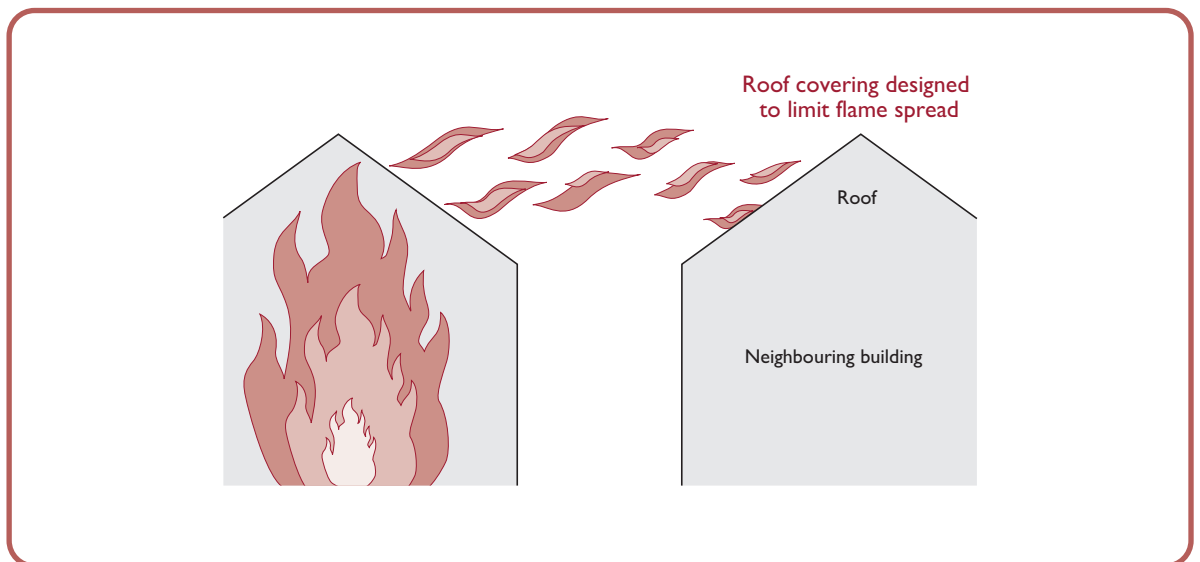

Figure 3. Fire spread by airborne burning brands

Where there is the potential for fire spread from one building to another (e.g. when it is located close to a site boundary) the Approved Document may recommend restrictions on the flame spread characteristics of roof coverings and external wall surfaces. It may also be necessary to make all or part of an external wall fire resisting [9], to limit the heat radiation to an adjacent building or boundary.

3 General information and regulatory requirements

Building regulations for England, Wales and Northern Ireland

The extent to which any external wall needs to be fire resisting or meet flame spread criteria depends on a number of factors:

- use of the building
- area of the wall
- distance of the wall from the boundary or adjacent buildings.

The relevant boundary will often be the site boundary but when buildings on the same site are used for residential or assembly purposes or they are under separate operational control it is necessary to consider fire spread to a notional boundary located between them. The allowable unprotected areas are then calculated accordingly.

The main recommendations of the Approved Document are summarised below.

3.3.3 External walls within 1000mm of boundary

Any part of an external wall within 1000mm of a relevant boundary should have:

- Class 0 or Euroclass B external surface;
- fire resistance (integrity and insulation) to the same standard as required for the building structure;
- Very restricted window openings (see Figure 4).

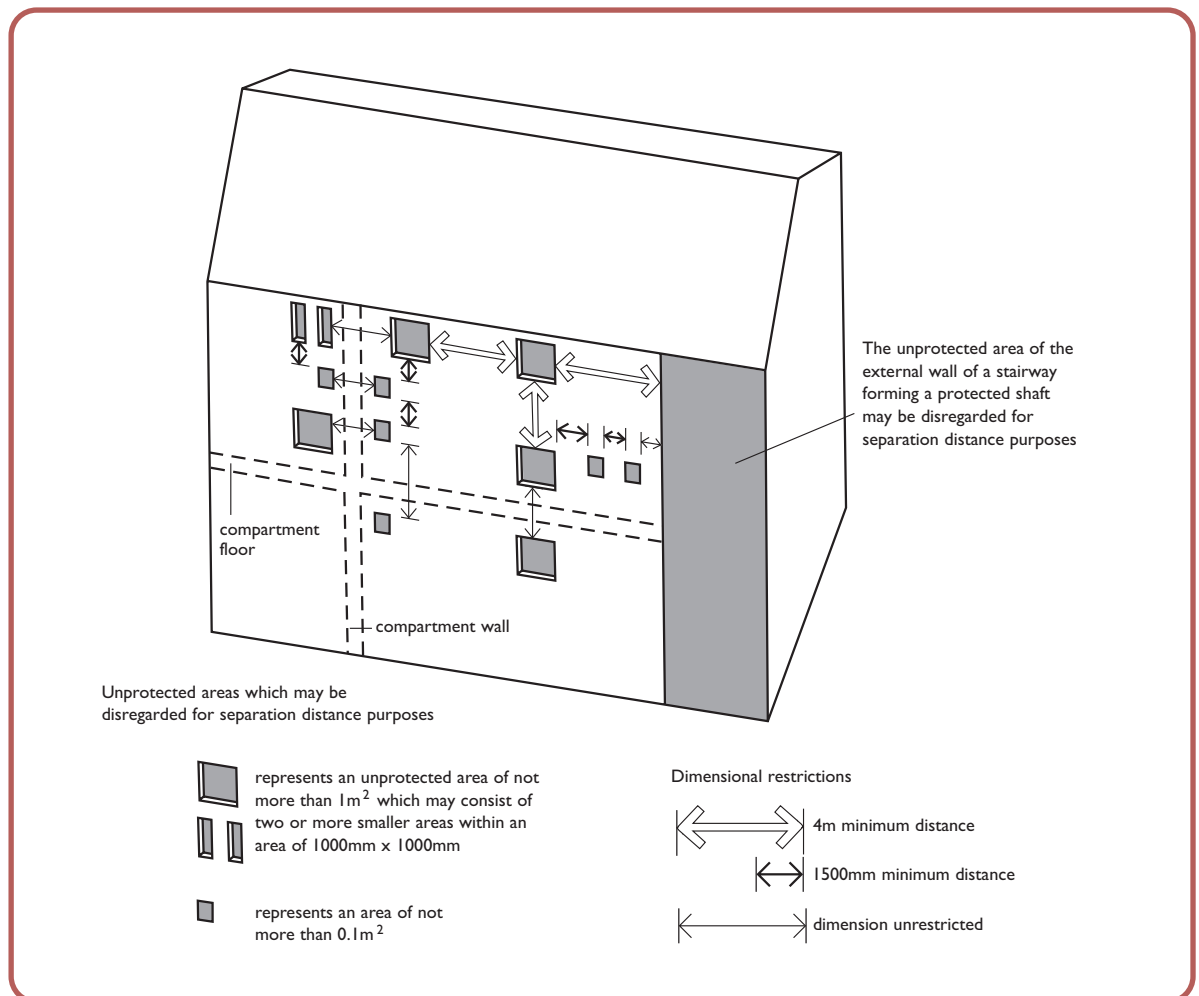

Figure 4. Limitation on window openings within 1000mm of boundary

3.3.4 Walls more than 1000mm from boundary

If a wall is located more than 1m from the boundary it may still be necessary for all or part of it to be fire resisting.

Figure 5 indicates the separation distance required to ensure that there will be no restriction on unprotected area for various areas of wall. This graph indicates the maximum separation distance required for walls of various areas. In practice a rectangular wall will require a lesser separation distance than that indicated (derived for a square elevation) but the figure provides a useful quick check to establish whether there may be a restriction on the unprotected area.

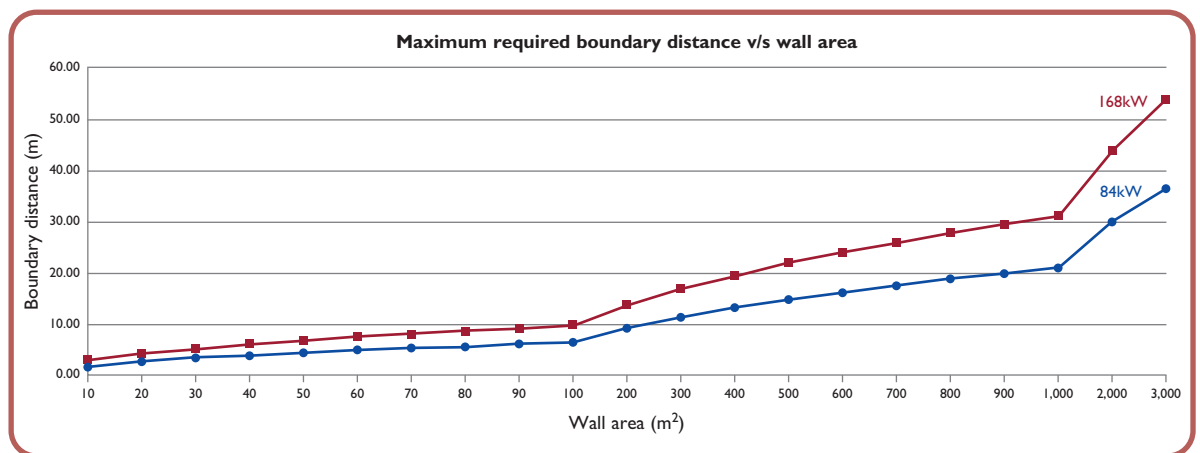

Figure 5. Maximum required distance to boundary for various wall areas

The upper (red) line is applicable to buildings in the shop, commercial, storage or other non-residential purpose groups.

The lower (blue line) applies to open sided car parks, residential, office and assembly buildings.

When the allowable extent of unprotected areas (i.e. the area that does not require fire resistance) has been determined the remaining protected areas should satisfy the following criteria:

- external surface to be non-combustible; or any combustible surface more than 1mm thick to be Class 0 or Euroclass B;
- fire resistance as regards integrity to the same standard as the other building elements and an insulation value of 15 minutes (when tested from the inside);

Where life safety sprinklers are provided throughout the building in accordance with BS EN 12845 the boundary distance may be halved or the unprotected area doubled.

3 General information and regulatory requirements

Building regulations for England, Wales and Northern Ireland

3.4 Roof coverings

The specification of roof coverings varies according to the distance of the building from the boundary. No restriction is placed on the use of roof coverings designated AA, AB or AC to BS 476 Part 3: 2004 [10] or Euroclass B_{roof}(t4) to BS EN 13501-5 [11] but lower ratings are acceptable if the building is 6m or more from the boundary.

Insulated panels with metal facings and standard plastisol/polyurethane protective coatings intended for use in the external envelope generally have a test designation AA, AB or B_{roof}(t4) and are suitable irrespective of the distance from the boundary.

Unless roof decking is used as an escape route it is not considered to be an element of structure and does not normally require to be fire resisting. However, any part of a roof that forms an escape route should provide a fire resistance of at least 30 minutes fire resistance with regard to load bearing capacity, integrity and insulation. This requirement generally precludes the use of insulated panels for sections of a roof that form part of an escape route.

3.5 Junctions with compartment walls and floors

Junction with external walls

This guide does not deal with the construction of internal compartment walls but where a roof or external wall meets a compartment wall it is necessary to ensure that the junction does not compromise the fire resistance.

This is usually achieved by fire stopping the junction with materials of limited combustibility to seal any gaps in the construction. There are a number of different techniques that may be used to fire stop such junctions but figure 6 shows an effective means of achieving a satisfactory junction detail.

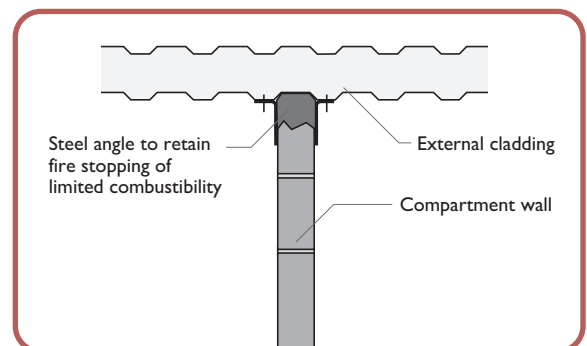

Figure 6. Illustration (on plan) of recommended fire stopping detail

Junction with roofs

Where an insulated panel is used in roof construction and passes over a compartment wall the Approved Document recommends that a 300mm wide band of material of limited combustibility should be provided where a composite panel passes over the wall.

This implies the use of a mineral fibre core panel or removal of a 300mm wide strip of combustible core material and its replacement with an alternate material of limited combustibility (e.g. mineral fibre). This is difficult to achieve in practice. However, experience from real fires has shown that PIR cored insulated panel systems, fully filled and auto-adhesively bonded do not propagate fire within the core, and are acceptable without the 300mm strip* if the performance of the specific product meets the requirements of LPS 1181.

*Advisory guidance note: Building Regulations Fire Safety (Part B) – Buildings other than Dwelling Houses FAQs
www.planningportal.gov.uk/buildingregulations/approveddocuments/partb/faqs/other

“However, an alternative approach might be to use a panel system which has been shown in a large scale test to resist internal and external surface flaming and concealed burning.”

At compartment wall junctions it is also recommended that the roof covering should be designated AA, AB or B_{roof}(t4) for a distance of 1500mm on each side of the wall. This is satisfied by metal faced insulated panels intended for external roof applications, which in general have an AA or AB classification.

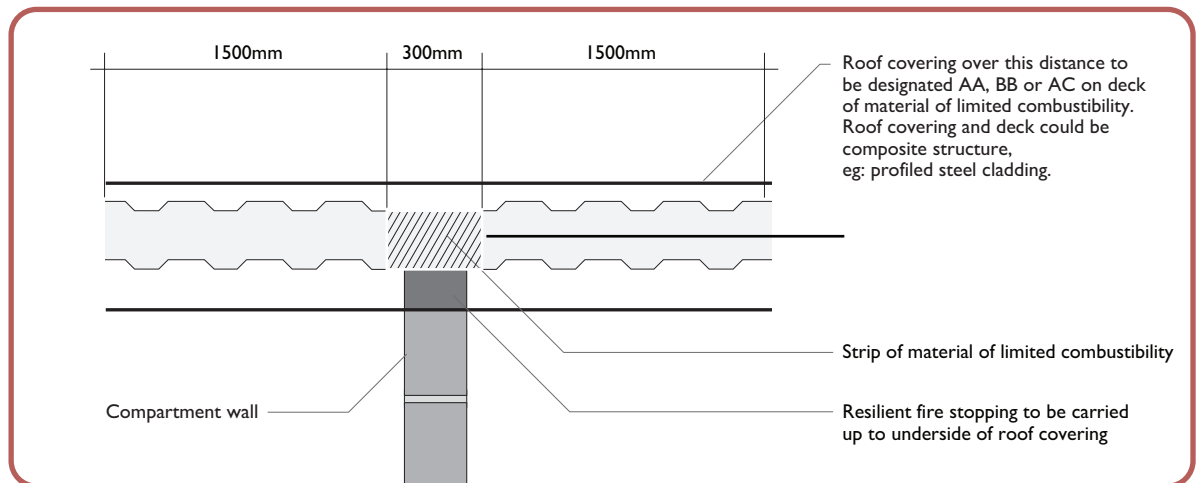

Figure 7. Illustration of the 1500 mm extent of AA, AB or AC material and the 300mm wide strip of material of limited combustibility (not required for panels meeting LPS 1181)

3.6 Cavity barriers in concealed spaces

An important part of requirement of B3 is the recommendation to close off the perimeter of hidden voids and provide protection where a void passes a compartment wall or floor.

Cavity barriers are also usually required to subdivide large concealed spaces such as the void behind a suspended ceiling at 20 m intervals. (This is reduced to 10m if the internal surfaces of the void are not Class I or Euroclass C).

There are no cavities within insulated panels because the insulating core completely fills the space between the two faces of the panel.

An area that is relevant to the external envelope, where the necessity to provide cavity barriers or continue a fire resisting wall is often forgotten, is at the eaves where a pitched roof meets an external wall [Figure 8].

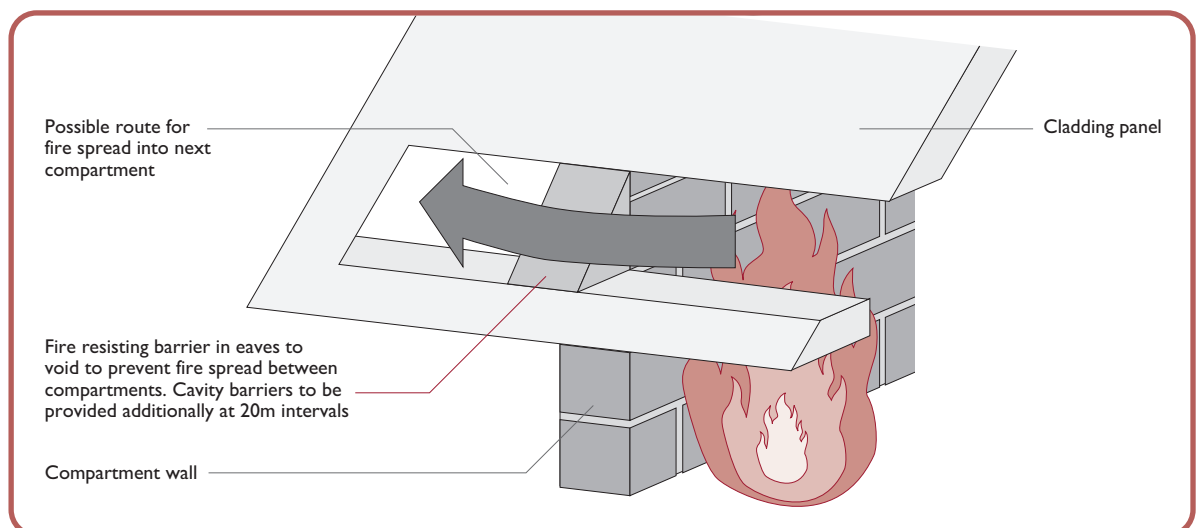

Figure 8. Illustration of required fire resisting barrier and cavity barrier at eaves

3 General information and regulatory requirements

Building regulations for England, Wales and Northern Ireland

3.7 Summary

Table 3 summarises the main recommendations of Approved Document B that are relevant to the specification of insulated panels used in external walls.

Table 3. Main recommendations of Approved Document B for external walls

Room size	Internal face*	External face*	Fire resistance	
			Integrity	Insulation
Small rooms less than 30m ²	Class 3 [Euroclass D]			
Other rooms	Class 1 [Euroclass C]			
Circulation spaces	Class 0 [Euroclass B]			
Boundary distance				
Less than 1m	Class 0 [Euroclass B]		Yes ¹	Yes ¹
Greater than 1m protected areas unprotected areas		Class 0 [Euroclass B] N/A	Yes ¹ N/A	15mins N/A
Height of wall above ground				
Less than 18m		N/A ¹		
Greater than 18m		Class 0 [Euroclass B] ³		
External escape stair				
Stair located within 1.8m of wall			30	N/A

Notes to table 3

* Most commercially available external insulated panels will achieve Class 0 or Euroclass B and will therefore satisfy the most onerous flame spread requirements of the Approved Document.

1. Fire resistance period as required for the building structure.
2. In assembly and recreation buildings (purpose group 5) the external face should have an index (I) = 20 when tested to BS 476: Part 6 or Euroclass C to a height of 10m above any external level to which the public have access.
3. In any part of the wall below 18m this may be reduced to index (I) = 20 when tested to BS 476: Part 6. Panels with Class 0 or Euroclass B meet this requirement.

4 General information and regulatory requirements

Building Standards – Scotland

Introduction

The design and construction for fire safety in buildings in Scotland is controlled by the Building (Scotland) Regulations 2004 (as amended)[3].

The requirements in relation to fire safety are set out in Section 2 of Schedule 5 of the Regulations which sets out requirements for items such as:

- Compartmentation
- Structural protection
- Internal linings
- Fire spread to neighbouring buildings
- Internal linings
- Fire spread on external walls
- Escape
- Fire Service access
- Other

These Regulations are supported by two Technical Handbooks, one for domestic properties and one for non-domestic properties.

Guidance on meeting the functional requirements of the Building (Scotland) Regulations with relation to fire safety is found in Section 2 of the Technical Handbooks.

The main provisions of these handbooks as they relate to the external building envelope are summarised below.

Fire spread to neighbouring buildings

To minimise the risk of fire spread between adjacent buildings all or part of the external wall may need to be fire resisting.

Walls not more than 1m from boundary

External walls within 1m of a boundary must be fire resisting, in accordance with Table 4 (page 20).

Walls more than 1m from a boundary

Other than the allowable unprotected areas, external walls more than 1m from the boundary should be fire resisting in accordance with Table 4 (page 20).

Where the external wall is more than 1m from the boundary, buildings requiring 'Short' duration of fire resistance (30 minutes) are not required to satisfy the insulation criterion of the fire resistance test.

Unprotected area

On walls more than 1m from the boundary, the amount of area that does not need to be fire rated (unprotected area) can be calculated using the guidance given in the technical standards.

If an automatic fire suppression system is provided in buildings requiring medium (60 minutes) fire resistance (e.g. storage, shops and entertainment usage) then the allowable unprotected area can be calculated using the figures for buildings requiring low (30 minutes) fire resistance.

The assessment of allowable unprotected areas is beyond the scope of this guide but detailed guidance on the calculation of space separation and unprotected areas is given in Section 2.6.3 of the Technical Handbooks and also in the BRE report BR187[12]. An initial check on whether there may be a restriction on unprotected areas may be made using Figure 5 in section 3.

4 General information and regulatory requirements

Building standards – Scotland

4.1 Fire resistance of external walls

Where an external wall needs to be fire resisting, it need only be fire resisting from the inside. Table 4 indicates the required period of fire resistance for various types of building use.

Table 4. Required period of fire resistance for varying types of building use

Use of building	Not more than 1m from boundary		More than 1m from boundary	
	No fire suppression system	Fire suppression system	No fire suppression system	Fire suppression system
Assembly	Medium	Medium ^{2c}	Medium ^{1, 2c}	None
Entertainment	Medium	Medium ^{2b}	Medium ^{2b}	Medium ¹
Factory or storage	Medium	Medium	Medium ³	Medium ^{1, 4}
Residential	Medium	Medium ^{2b}	Medium ^{1, 2b}	None
Residential care or hospital	Medium	Medium	Medium	None
Shop	Medium	Medium ^{2a}	Medium ^{2a}	Medium ¹
Office	Medium	Medium ^{2d}	Medium ^{1, 2d}	None
Open sided car park	Short	Short	None	None

Notes:

1. Short fire resistance duration is sufficient where the building is single-storey.
 2. Short fire resistance duration is sufficient where the building is a multi-storey building and the area of any compartment does not exceed: (a) 500 m² (b) 1000 m² (c) 1500 m² (d) 2000 m² (e) 3000 m² and (f) 4000 m².
 3. Short fire resistance duration is sufficient where the building is a factory (Class 2), and is single-storey.
 4. No fire resistance duration is necessary where the building is a factory (Class 2).
- Short fire resistance equates to 30 minutes, medium fire resistance equates to 60 minutes.

4.2 Detached buildings in the same occupation

Under Scottish regulations, it is always necessary to consider fire spread between buildings, even when on the same site and under the same management – see Figure 9.

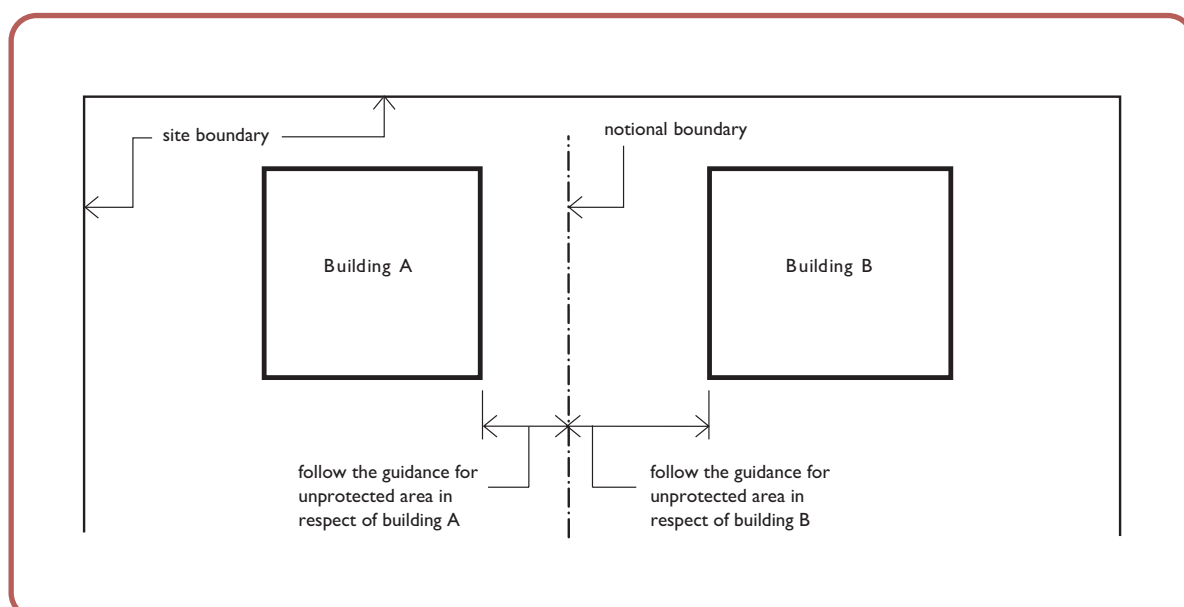

Figure 9. Establishing notional boundaries between buildings

Additionally, when a single building has compartments that face each other externally, it is necessary to establish whether unprotected areas need to be restricted by setting a notional boundary between the two compartments.

4.3 Combustibility

Every part of an external wall that is 1m or less from a boundary should be constructed of non-combustible materials.

In buildings more than 18m above ground any insulation material situated or exposed in a cavity formed by external wall cladding should be non-combustible.

This potentially restricts the use of insulated panels with combustible cores in buildings located close to the boundary or with a top storey at more than 18m above ground.

4.4 Fire spread – external wall cladding

On walls that are more than 1m from boundary, combustible cladding is acceptable, however, if it is more than 1mm thick it must be included in the unprotected area calculation as it may contribute to the fire size once the fire has broken out of a window/door. Combustible cladding more than 1mm thick should be constructed from materials with a reaction to fire in accordance with Table 5:

Table 5. Combustibility classifications according to building and location

Building height	Building type	Location	Maximum level of risk
Not more than 18m above ground	Entertainment and assembly	Not more than 10m above ground (or above a roof or any part of the building to which the general public have access)	Low risk
		10-18m above ground	Very high risk
	Residential care and hospitals	Any	Low risk
	All other	Any	Very high risk
More than 18m above ground	Any	Any	Low risk

Note: See Reaction to Fire table at the end of this section.

Most commercially available insulated panels designed for use in the external building envelope will be classified as low risk and will therefore satisfy the most onerous flame spread requirements of this table.

4 General information and regulatory requirements

Building standards – Scotland

4.5 Fire spread from neighbouring buildings – Roof coverings

In order to resist the penetration or ignition by fire from an external source and limit the vulnerability of its external surface, the roof covering, (including any roof lights) should meet the requirements set out in Table 6 and Table 9.

Table 6. Fire acceptable roof coverings

Distance to boundary	Vulnerability
Not more than 6m	Low
Not more than 24m	Low or Medium
More than 24m	Low, Medium or High

Note: See Vulnerability of Roof Coverings table at the end of this section.

Most commercially available insulated panels designed for use in the external building envelope will be classified AA or AB in accordance with BS 476 Part 3 and will therefore satisfy the most onerous flame spread requirement in table 6 (i.e. low vulnerability).

4.6 Junctions

4.6.1 Junctions with walls

Where a compartment wall or compartment floor (including a fire resisting ceiling) forms a junction with an external wall, the junction should maintain the fire resistance of the compartment wall or compartment floor.

This is usually achieved by fire stopping with non-combustible material to seal any gaps in the construction (see Figure 6, page 16).

4.6.2 Junctions with roofs

Where a compartment wall forms a junction with a roof, the junction should maintain the fire resistance duration of the compartment wall in accordance with the following:

- where the roof has a combustible substrate, the wall should project through the roof to a distance of at least 375 mm above the top surface of the roof; or
- where the wall is taken to the underside of a non-combustible roof substrate, the junction should be fire-stopped and the roof covering should be low vulnerability for a distance of at least 1.7 m to each side of the centre-line of the wall.

This generally requires that a non-combustible break be provided within the core of an insulated panel with a combustible core. However, if proven by a suitable fire resistance test that a particular roof system does not impair the fire resistance of a wall, omission of the non-combustible break may be acceptable.

4.7 External escape routes

If an external escape stair is located within 2m of an external wall every part of the wall below the stair and within 2m of the stair should be fire resisting for a short duration (i.e. 30 minutes).

In some cases it may not be possible to freely disperse away from the building (e.g. where the final exit door discharges to an enclosed outdoor space). In such cases, where there is only one route of escape, the external wall of the building within 2m of the route of escape should have a short fire resistance duration for integrity up to 1.1 m above the adjoining ground.

Any part of a roof that forms an escape route should be fire resisting as regards load bearing capacity, integrity and insulation. Similarly if the roof performs the function of a floor it should have the same fire resistance as is required for other floors within the building. This requirement would generally preclude the use of insulated panels for sections of roof that form part of a floor or escape route.

4.8 Cavity barriers

An important part of the Technical Handbooks is the requirement to close off the perimeter of hidden voids and provide fire barriers where a void passes a compartment wall or floor.

Cavity barriers are also usually required to subdivide large concealed spaces such as the void behind a suspended ceiling at 20m intervals (this is reduced to 10m if the internal surfaces of the void are not medium or low risk (Class 1 or Class 0 or Euroclass B or C).

Because the insulating core completely fills the space between the two faces of an insulated panel, extensive cavities are only likely to arise when separate internal linings or suspended ceilings are provided.

However, an area that is relevant to the external envelope where the necessity to provide fire resisting and cavity barriers is often forgotten is at the eaves where a pitched roof meets an external wall (see figure 8, page 17).

4.9 Internal linings

Where an insulated panel forming part of an exterior wall also forms part of the interior lining of a building, the interior face must meet the surface spread of flame classification from Table 7 (see also Reaction to Fire Table 8 at the end of this section):

Table 7. Surface spread of flame according to building type and area

Building	Residential care buildings and hospitals	Shops	All other buildings
Room not more than 30m ²	Medium risk ²	High risk	High risk
Room more than 30m ²	Low risk ³	Medium risk	Medium risk ⁴
Unprotected zone	Low risk	Low risk ⁵	Medium risk
Protected zone and fire-fighting shaft	Low risk	Low risk	Low risk

Notes:

1. Including any toilet or washroom within a protected zone.
2. High risk in a room not greater than 4m².
3. Ceilings may be medium risk.
4. Low risk in storage buildings (Class 1).
5. In an enclosed shopping centre, structural timbers supporting glazing that forms part of a shop front, unit signs and stallboard risers can be constructed of materials which are low, medium or high risk provided they are not more than 20% in total, of the area of the shop front.

4 General information and regulatory requirements

Building standards – Scotland

Table 8. Reaction to fire – risk classifications

Risk	British Standards	European Standards
Non-combustible	Certified non-combustible in accordance with BS476: Part 4[13]. Does not flame or cause any rise in temperature on either the centre or furnace thermocouples in accordance with BS476:Part 11[14]	Classified A1 in accordance with BS EN 13501-1[8].; or Classified A2-s3, d2 in accordance with BS EN 13501-1
Low risk	Class 1 in accordance with BS 476: Part 7[6]; and Has an index of performance (I) not more than 12 and a sub-index (iI) not more than 6 in accordance with BS 476: Part 6. 2004[3]	B-s3, d2 or better in accordance with BS EN 13501-1
Medium risk	Class 1 in accordance with BS 476: Part 7	C-s3, d2 or better in accordance with BS EN 13501-1
High risk	Class 2 or Class 3 in accordance with BS 476: Part 7	D-s3, d2 or better in accordance with BS EN 13501-1
Very high risk	Does not attain the recommended performance for high risk	

Note: More detail can be found in Annex 2D of the Technical Handbooks.

Table 9. Vulnerability of roof coverings

Vulnerability	British Standards	European Standards
Low	Designation AA, AB or AC in accordance with BS 476: Part 3[10]	$B_{\text{roof}}(t_4)$ in accordance with BS EN 13501: Part 5[11]
Medium	Designation BA, BB, BC, CA, CB or CC in accordance with BS 476: Part 3	$C_{\text{roof}}(t_4)$ and $D_{\text{roof}}(t_4)$ in accordance with BS EN 13501: Part 5
High	Any designation other than low or medium vulnerability.	$E_{\text{roof}}(t_4)$ and $F_{\text{roof}}(t_4)$ in accordance with BS EN 13501: Part 5

Note: More detail can be found in Annex 2F of the Technical Handbooks.

Summary of main recommendations of Scottish Technical standards

The main recommendations of the Building (Scotland) Regulations (Technical Handbook (Section 2 – Fire) as they apply to external wall panels are summarised in Table 10.

Table 10. Main recommendations of Technical Standards for external walls

Room size	Internal lining*	External lining*	Fire resistance	
			Integrity	Insulation
Small rooms less than 30m ²	High/medium ¹			
Rooms greater than 30m ²	High/low ¹			
Unprotected escape routes	Medium/low			
Unprotected escape routes	Low			
Boundary distance				
Not more than 1m allowable unprotected areas			Yes ²	Yes ²
Greater than 1m (protected areas only):				
a) buildings requiring medium fire resistance period		Non-combustible (up to 1mm thick) See table 5	Yes ²	30mins
a) buildings requiring short fire resistance period		Non-combustible (up to 1mm thick) See table 5	Yes ²	None
Height of wall above ground				
Not more than 18m		N/A ³		
More than 18m		Low ⁴		
External escape stair				
Stair located within 2m of external wall			30mins	30mins

Notes to table 10

1. Requirement varies according to building type.

2. Fire resistance period: short or medium depending upon building type.

3. In assembly and recreation buildings the external face should be categorized as of low risk for 10m above any external level to which the public have access. In hospitals all of the external face should be categorized as low risk.

4. If the floor of the top storey is greater than 18m only non-combustible core materials are acceptable.

* Most commercially available external insulated panels will comply with the most onerous requirements for internal linings.

5

Fire precautions in hospitals

Guidance on the design for fire safety in hospitals in England and Wales is given in the NHS Firecode suite of documents. Health Technical Memorandum 05-02 'Guidance in support of functional provisions for healthcare premises' (HTM 05-02 [15]) being the primary fire safety design code. It supersedes Health Technical Memorandum 81 and came into effect in April 2007. In Scotland separate guidance for hospitals is given in the Technical Handbooks.

The guidance in HTM 05-02 is designed to be applied to in-patient facilities such as acute hospitals.

Because of the presence of bed patients special provisions must be made for escape and compartmentation. However, recommendations regarding external cladding are generally consistent with other guidance in support of building regulations. This section summarises some of the main additional provisions that are applicable to the external envelope of hospitals. However, it is strongly recommended that reference be made to the relevant design guidance (HTM 05-02) and specific contractual requirements when specifying construction materials for hospital use.

5.1 Fire spread across internal surfaces

To inhibit the spread of fire and smoke within the building, provisions are made within HTM 05-02 to ensure that lining materials do not promote rapid flame spread. The main recommendations are summarised below in Table 11.

Table 11. Surface classification for wall and ceiling linings

Location	National classification	European classification
Circulation spaces	0	B-s3, d2
Small rooms (max 4m ²)	1	C-s3, d2
Other rooms	0	B-s3, d2

5.2 External fire spread

As with guidance for other building types, the fire resistance of external walls in hospitals depends upon the distance of the building from a boundary (either site boundary or notional boundary between buildings on the same site).

It is important to note that in hospital buildings it is also necessary to consider the potential for fire spread between compartments within the same building e.g. it may be necessary to limit the unprotected areas of compartments facing each other across a lightwell.

HTM 05-02 provides a method for calculating unprotected areas for buildings up to 12m high. Above this height the guidance given in BRE report BR 187 [12] should be adopted. Where parts of an external wall are required to be fire resisting due to its proximity to a boundary, the period of fire resistance should be in accordance with Table 12.

Table 12. Fire resistance requirements according to height

Height of the top floor	Minimum period of fire resistance
Not more than 5m	30 minutes
Over 5m	60 minutes

Notes:

1. The minimum period of fire resistance relates to integrity. The minimum provision for insulation is 15 minutes unless the external wall is less than 1000 mm from a boundary or adjacent building, when the requirement for insulation should be the same as that for integrity.
2. An external wall that is also an element of structure may require additional fire resistance in accordance with Table 2 of HTM 05-02.

5.3 Surfaces of external walls

The surfaces of external walls of hospitals should provide a surface spread of flame classification of national Class 0 or European Class: B-s3,d2.

5.4 Roof coverings

Roof coverings should comply with the criteria given in Approved Document B (see Section 3).

5.5 Junction of walls and low level roofs

Where a low level roof abuts an external wall, the roof is required to provide a minimum period of fire resistance of 60 minutes (integrity and insulation) for a distance of 3 metres from the wall (see Figure 10). This recommendation is designed to prevent fire spread through the lower roof and into the upper levels of the building. This requirement need not be applied when sprinklers are installed throughout the relevant areas.

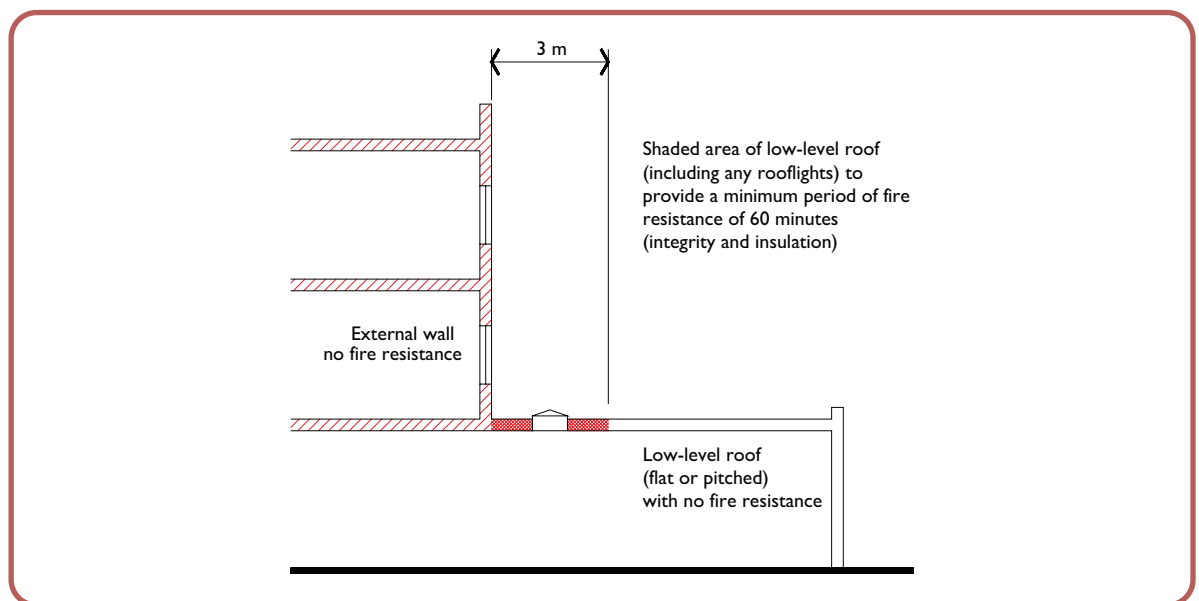
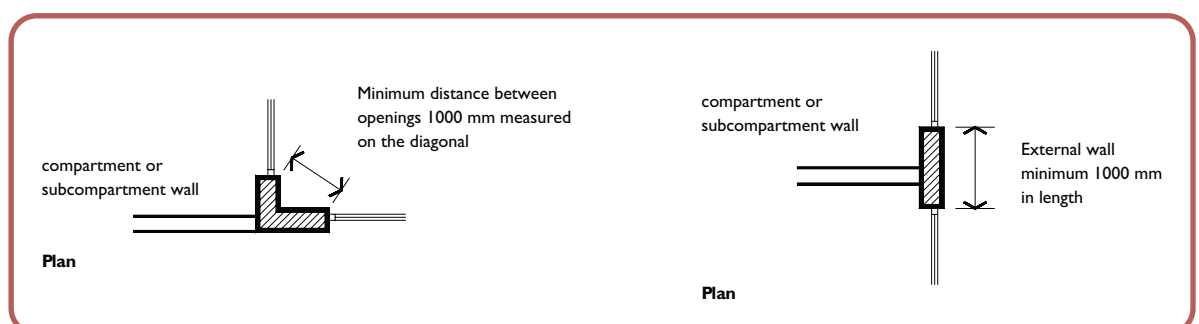

Figure 10. Junction of walls and low level roofs

5.6 The junction of compartment walls and floors with external walls

Where a fire resisting compartment wall, sub-compartment wall or a protected shaft meets an external wall, HTM 05-02 recommends that a one metre-wide strip of fire resisting construction should be provided at the junction. The strip should have the same fire resistance as the compartment wall. This is done to reduce the potential for fire spread between compartments. In cases where sprinklers are installed on both sides of the compartment wall this requirement does not apply.



5 General information and regulatory requirements

Fire precautions in hospitals

5.7 Specification of panel core materials

HTM 05-02 states that when considering the use of such cladding, reference should be made to the requirements of Approved Document B and the panel in-fill material, when involved in a fire, should not compromise the safety of occupants remaining in the building either through fire or through smoke spread and wherever possible, cladding with a non-combustible core should be used.

The guide then goes on to say: the following are examples of core materials that may be appropriate to the application concerned.

Mineral fibre cores

- cooking areas;
- hot areas;
- fire breaks in combustible panels;
- fire-stop panels;
- general fire protection;
- external cladding.

All cores

- chill stores;
- cold stores;
- clean rooms.

Core materials may be used in other circumstances where a risk assessment has been made and other appropriate fire precautions have been put in place.

5.8 Risk assessment in hospital design

External insulated cladding panels are commonly used in hospital construction following the outcome of risk assessment. In particular the fire risk assessment needs to consider the extent to which PHE (progressive horizontal evacuation) is being adopted and how far people will be moved initially and subsequently should that become necessary, along with the availability of a sufficient number of suitably trained staff and adequate resources to perform the evacuation. This needs to be weighed against the potential effects of a fire involving cladding materials with a combustible core, and how that might affect the occupants remaining in the premises.

Additionally for the purposes of a new building (or a refurbishment) where cladding with a combustible core is intended to be specified, the Building Control Body (BCB) would need to understand the intended fire strategy for the premises and consider the manufacturer's technical information on the cladding proposed, to assess any potential implications. As the lead authority for fire safety in new buildings subject to building control approval, the final decision lies with the BCB.

Fire test certification for both reaction and resistance to fire, insurance industry approvals, additional fire test reports and real fire case study information is generally very helpful in informing the risk assessment about the performance of PIR core panels.

6

General information and regulatory requirements Fire precautions in schools

6.1 Approved Guidance

Building Bulletin 100 (BB100) [16] is a design guide showing how the functional requirements of the Building Regulations may be met when designing new schools or extensions to existing schools.

BB100 is largely based upon Approved Document B and much of the guidance remains the same as in the Approved Document.

However, the main differences between the two guides arise because BB100 covers the protection of the building fabric and contents of schools whereas the Building Regulations are only concerned with the safety of people.

Each year around 1 in 20 schools experiences a fire and nearly 60% of school fires are started deliberately. Fire damage to the building structure and contents has obvious cost implications but the key objectives are also to minimise disruption to schoolwork, coursework and morale.

To address these issues, BB100 goes beyond the requirements for life safety and also includes recommendations for property protection. The biggest implication of these recommendations is that almost all new secondary school developments will need to incorporate an automatic sprinkler system.

A large proportion of schools in the UK are insured by the Zurich Insurance Company. Consequently, Zurich has produced its own guide, entitled “School and Academy design – A guide to the design and protection of School and Academy buildings”.

As mentioned above, BB100 is based upon ADB, and the recommendations made within ADB that relate to insulated panels are all replicated in BB100. Therefore reference should be made to Section 3 of this guide when specifying insulated panels in schools. The following sections identify areas in which the guidance in BB100 and the Zurich guide differ from the guidance of Approved Document B in areas that relate to the use of insulated panels.

6.2 Specifying Insulated Panels

The Zurich guidance states that Insulated Panels are acceptable if they are LPCB approved to LPS 1181 [17].

LPS 1181 Part 1 – “Requirements and Tests for Built-up Cladding and Sandwich Panel Systems for Use as the External Envelope of Buildings” provides for 2 main grades of products:

- Grade EXT-A. A product that satisfies the requirement for both ‘fire resistance’ (i.e. BS 476 Part 22 [9]) and ‘reaction to fire’ test (ie. LPS 1181 Part 1).
- Grade EXT-B. A product that satisfies the ‘reaction to fire’ requirement (i.e. LPS 1181 Part 1) only.

Because of the high incidence of external fires in schools environments, only wall panels complying to Grade EXT-A will be acceptable for walls and these must have a minimum integrity and insulation of 30 minutes. For roofs Grade EXT-A or B panels are acceptable although generally fire resistance is not a requirement.

6.3 External flame spread

As mentioned above, the majority of fires in schools are started deliberately and there is a high incidence of fires being started adjacent to the external walls. BB100 recommends that in order to mitigate the risk to the building from a fire started externally, combustible cladding for the ground floor level should not normally be specified (although it may form part of a fire engineered solution).

The Zurich guidance also states that insulated panels must not be used at low level because of the potential impact damage that educational buildings of this type may be subject to.

6 General information and regulatory requirements

Fire precautions in schools

6.4 Fire spread between buildings

When considering the potential for fire spread between buildings, it may not be necessary to deal with fire spread between adjacent school buildings on the same site if the fire alarms are linked and there would not be any threat to life safety posed by the potential fire spread across the site.

However, for property protection, BB100 recommends that the distance to notional boundaries between school buildings on the same site be considered (see Figure 11).

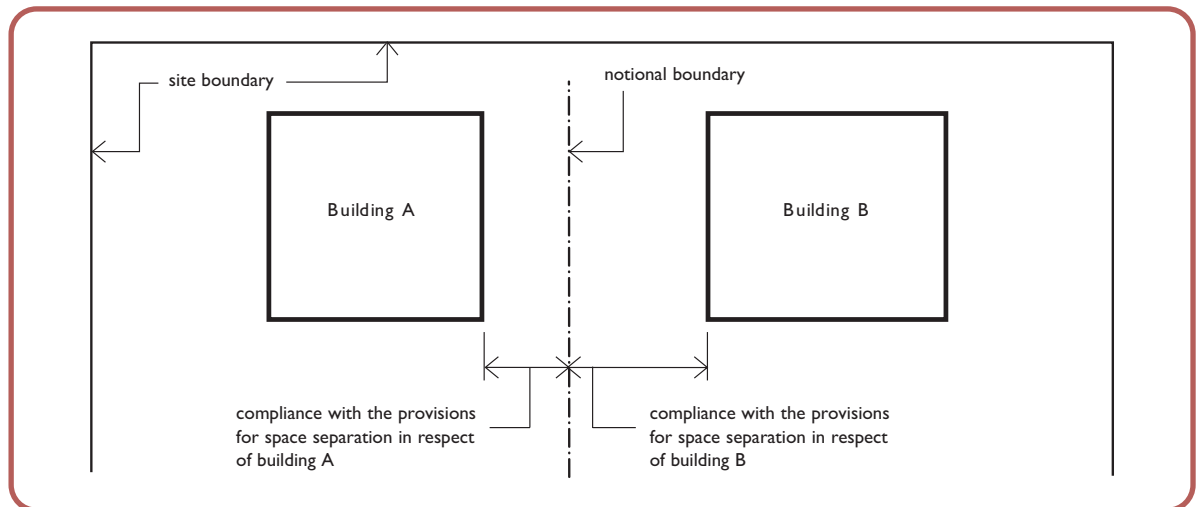

Figure 11. Illustration of notional boundary between buildings

The consideration of notional boundaries between school buildings may result in more onerous conditions being applied to the unprotected (non-fire resisting) areas of the façade of the building, the classification of the cladding system and also the designation of roof coverings.

6.5 Internal linings

Where an insulated panel forming part of an exterior wall also forms part of the interior lining of a school, the interior face must meet the surface spread of flame classification from Table 13.

Table 13. Surface spread of flame classifications

Location	National class	European class
Small rooms of not more than 30m ²	3	D-s3, d2
Other rooms	1	C-s3, d2
Other circulation spaces	0	B-s3, d2

6.6 Conclusions

In essence the recommendations provided in Building Regulations Guidance such as Approved Document B is supplemented with the following provisions:

- Insulated panels should not be used as cladding at ground floor level because of the potential for impact damage
- Insulated panels used in wall construction at first floor and above should meet the requirements for Grade EXT – A for 30 minutes fire resistance when tested in accordance with LPS 1208 and LPS 1181 Part 1.
- Fire spread between buildings on the same site should be controlled by setting a notional boundary between the buildings.

7

General information and regulatory requirements Business and property protection

7.1 Introduction

Fire safety legislation is primarily concerned with the protection of people from death or injury in fire.

However, a fire that causes no physical injuries can still have potentially devastating effects on the viability of a business in terms of:

- loss of stock;
- loss of records;
- direct damage to building;
- lost production;
- lost customers;
- damage to public image;
- etc.

Therefore, where a fire has the potential to have a substantial impact on the viability of a business or cause large financial losses consideration should be given to additional fire protection measures over and above those necessary to satisfy the minimum statutory requirements. Insurance premium discounts may be available where a high standard of fire protection is provided.

In some cases insurance cover may not be readily available unless fire protection measures exceed the minimum requirements of building regulations.

7.2 Low risk solution – external insulated panels

Buildings have to comply with the statutory requirements for Energy Conservation. By definition this demands well insulated structures and the Amendments to the Building Regulations: L2: 2010 further extend these requirements.

The revised regulations mean thicker roof and wall systems and increasingly airtight building envelopes. The recommendations in this guide combine the requirements to achieve these regulations with the steps necessary for fire safety and performance through the securement of external insulated panels and the design detailing to provide good fire protection.

The knowledge and understanding of how Insulated Panels perform in fire has advanced dramatically over the past 15 years through large scale fire tests and by extending this knowledge to the detailed analysis of actual case histories (see Section 11). As a result Insulated Panels are regarded as relatively low risk with limited contribution to and propagation in a fire scenario.

7.3 Insurance requirements

The Loss Prevention Council (LPC) have published a Design Guide for the Fire Protection of Buildings [18] for use by insurers when assessing the insurance premiums of premises that are considered to be of high value or risk.

The LPC Design Guide contains wide ranging recommendations for the fire protection of industrial and commercial buildings. These recommendations are aimed towards minimising the direct and indirect losses that may occur as a result of fire damage and business disruption.

The provisions in the LPC Design Guide for the Fire Protection of Buildings are important and should be taken into account. In some cases insurers may be unwilling to take on a specific risk. It is therefore important to establish, at an early stage, whether the insurers or the client have any specific requirements for property protection over and above building regulations requirements.

7 General information and regulatory requirements Business and property protection

Some of the more significant recommendations of the LPC guide, relevant to the external building envelope, are summarised below. These recommendations would normally be in addition to the requirements of the relevant building regulations.

The LPC Design Guide recommends controls on the fire performance of materials used as the internal lining of a building. This includes the roofs and walls of the external envelope.

The use of insulated panels is considered acceptable if they are constructed of materials of limited combustibility. Wall and roof panels incorporating combustible materials are also deemed to be acceptable if they satisfy the requirements of the LPCB test standard LPS 1181 (Requirements and Tests for Built-up Cladding and Sandwich Panel Systems for use as the external envelope [17]). Further information on the LPS 1181 test is given in section 10.

Compartment walls

Where a compartment wall meets with an external wall or roof it is recommended that a protected zone be formed such that the external wall or roof (and its supporting framework) has a fire resistance of at least 30 minutes integrity and 15 minutes insulation when tested from each side in accordance with BS 476: Part 22. The fire resisting section of the external cladding should extend for a minimum of 1m each side of the compartment wall or to the next structural bay whichever gives the greater distance.

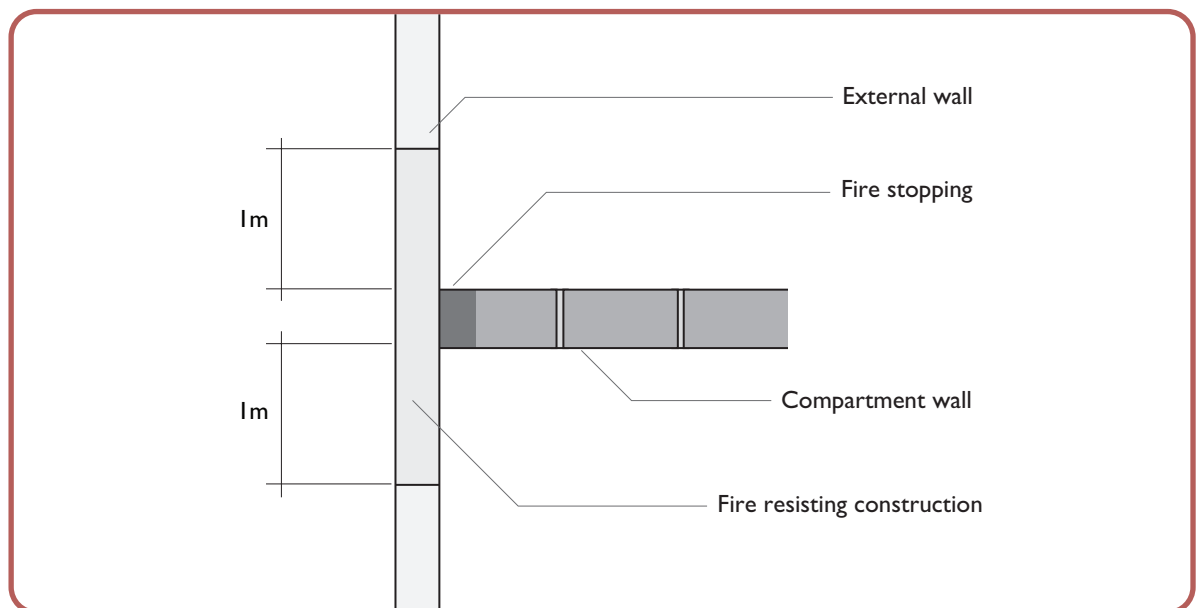
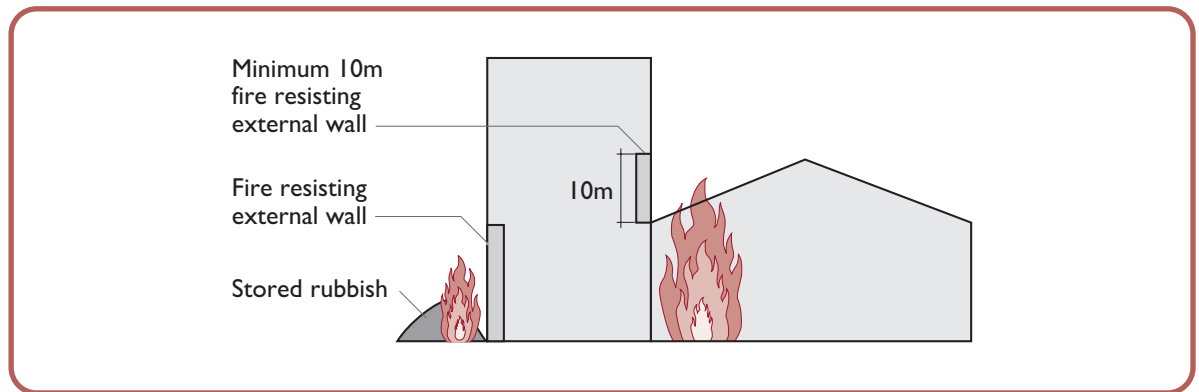

Figure 12. Illustration of protected zone on each side of fire resisting wall

In some circumstances where there is a potential threat of fire attack from the outside of a building (e.g. goods stored externally or an adjacent low roof (Figure 13)) the external walls may be required to provide a minimum of 30 minutes fire resistance (15 minutes insulation). Dependent upon the magnitude of the potential loss this may be increased to 60 minutes for both insulation and integrity.

Figure 13. Illustration of fire resisting external wall to protect against effects of an external fire



Roof coverings

The LPC guide recommends that roof coverings should be classified as AA, AB or AC when tested in accordance with BS 476: Part 3: 2004 [10].

Exposure to fire from external accidental sources

The LPC Design Guide also provides guidance on the prevention of fire spread from accidental fires and specifically the creation of firebreaks, or clear areas, between buildings and storage as well as from adjacent sites.

Figure 14 [taken from Chapter 5 of the LPC Design Guide] illustrates that by planning at an early stage any imposed risks can be eliminated, controlled or reduced to acceptable levels capable of protection. A specific recommendation is that provision should be made to prevent the storage of combustible materials nearer than 10m from the building and at a suitable distance from surrounding property or boundary fences or walls. External cladding having a degree of fire resistance (section 8.2) may also be considered to combat threats to the buildings posed by external sources of fire.

Figure 14. Outdoor exposure and arson risk – plan view

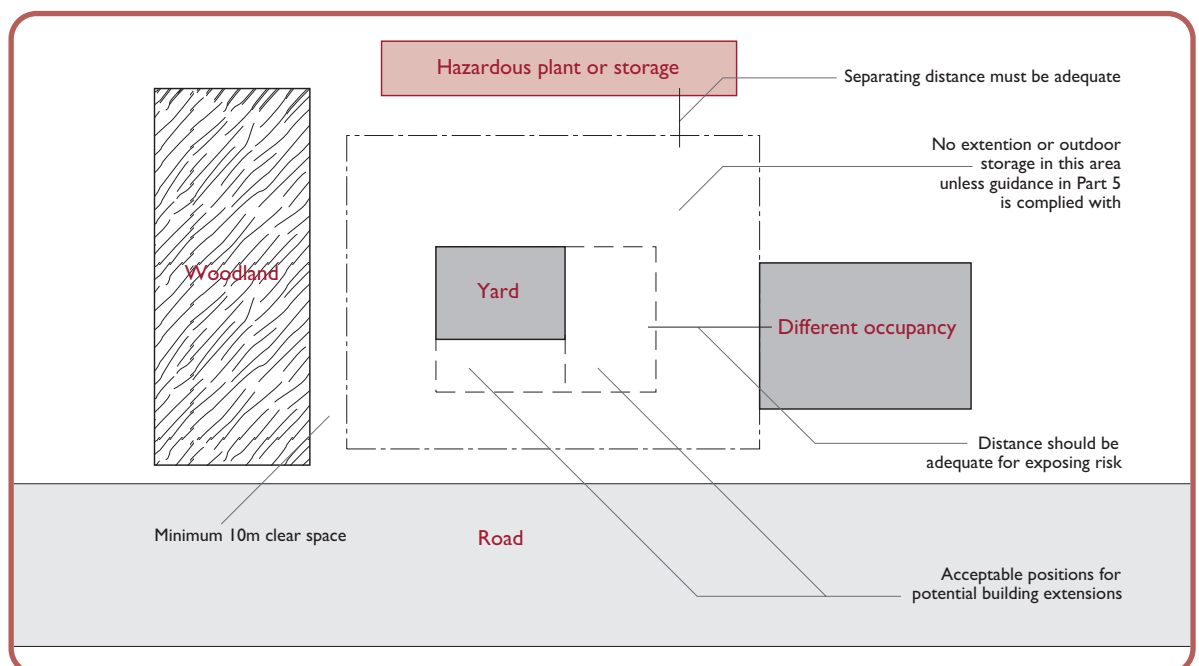

7 General information and regulatory requirements

Business and property protection

F M Global

F M Approvals, a fully owned subsidiary of FM Global is an insurance approval company which proactively supports good building design by means of a number of written documents and the approval testing of materials and services through the Factory Mutual Research Corporation.

FMRC approvals procedures encompass the testing of specific physical characteristics, e.g. wind uplift; foot traffic, in addition to fire characteristics.

In the case of insulated panels the standard used for the assessment of fire performance is FM 4880 'Approval Standard For Class I Fire Rating of Insulated Wall or Wall and Roof/Ceiling Panels, Interior Finish Materials or Coatings and External Wall Systems'. The latest version of this Standard was published in May 2010. This certification is based on a number of tests ranging from small scale to large scale covering the following.

- Density;
- Heat of Combustion – ASTM D3286-91a;
- Ignition Residue – ASTM D482-95;
- Flammability Characterisation – 50kW FM Approvals Flammability Apparatus;
- Surface Burning Characteristics – ASTM E84; and
- Room fire test – UBC 26-3

In addition to the above it is a requirement of approval to Class I with No Height Restriction that the material is capable of passing the FM Approvals 50ft High Corner Test For certification 'the assembly shall not support a self-propagating fire which reaches any of the limits of the 50ft (15.2m) high corner test structure as evidenced by flaming or material damage and ignition of the ceiling of the assembly in the 50ft (15.2m) high corner test shall not occur'. Alternatively approval to Class I with No Height Restriction can be achieved by appropriate performance in the FM Approvals 16ft parallel panel test.

Quality Management Systems

A key area of the LPC and FM approvals is the continued surveillance and audit checking of the Quality Management Systems for any approved insulated panel products to ensure that full compliance with product specification is maintained. The minimum requirement is ISO 9001:2000.

7.4 Loss prevention

The LPC design guide is essentially a prescriptive document that provides a series of standard solutions that may or may not be applied by insurers.

In many cases when considering property protection issues it may be more appropriate to utilise fire engineering and risk assessment techniques (see section 7) to determine appropriate fire protection measures and to establish the most cost effective means of reducing business risk.

For instance for a large manufacturing organisation it may prove to be more cost effective to divide operations between several dispersed locations rather than provide a very high level of fire protection to a single large operational centre.

8

General information and regulatory requirements Fire safety engineering

For simple buildings with traditional layouts, fire safety design can usually be achieved by referring to and complying with prescriptive codes and standards.

The Technical Handbooks for Scotland and Approved Document B in England and Wales are examples of prescriptive guidance used to meet the functional requirements of the respective countries' Building Regulations.

Complying with the recommendations of Approved Document B, Technical Booklet E (Northern Ireland) and the Technical Handbooks (Scotland) is not mandatory providing that it is explicitly demonstrated that the functional requirements of the regulations can be met in some other way.

Fire safety engineering techniques can be adopted as a means of demonstrating compliance with functional requirements of the Building Regulations. In many large and complex buildings fire safety engineering may be the only practical way of achieving and demonstrating a satisfactory standard of fire safety.

As the traditional prescriptive codes have to account for an almost infinite range of building designs they will rarely provide the optimum solution in terms of:

- life safety;
- property protection;
- cost effective fire protection;
- operational requirements.

The prescriptive approach will often not meet the needs of building owners, designers or approvals bodies, particularly for more complex buildings or processes, or in instances where there is a potential for substantial financial loss arising from a relatively small fire.

A particular weakness in the prescriptive approach was recognised in the conclusions of the Cullen report into the Piper Alpha offshore platform disaster, which stated that:

“Many regulations are unduly restrictive in that they are of a type that impose ‘solutions’ rather than ‘objectives’ and are out of date in relation to technological advances. There is a danger that compliance takes precedence over wider safety considerations...”

This conclusion is equally applicable to building design and BS 7974 (Application of fire safety engineering principles to the design of buildings [19]) has been developed to provide an objective based approach to the achievement of fire safety in buildings.

The main objectives of BS 7974 are to:

- a) provide a structured framework for assessing the interaction between buildings, people and fire.
- b) enable an objective assessment of the fire safety measures required to achieve defined objectives.
- c) assist in developing alternatives to prescriptive codes and enable the effect of these to be evaluated.

The British Standard divides the fire safety engineering design process into three main stages:

- Qualitative design review
- Quantitative analysis
- Assessment against criteria

The general approach adopted in the standard is illustrated in figure 15.

8 General information and regulatory requirements

Fire safety engineering

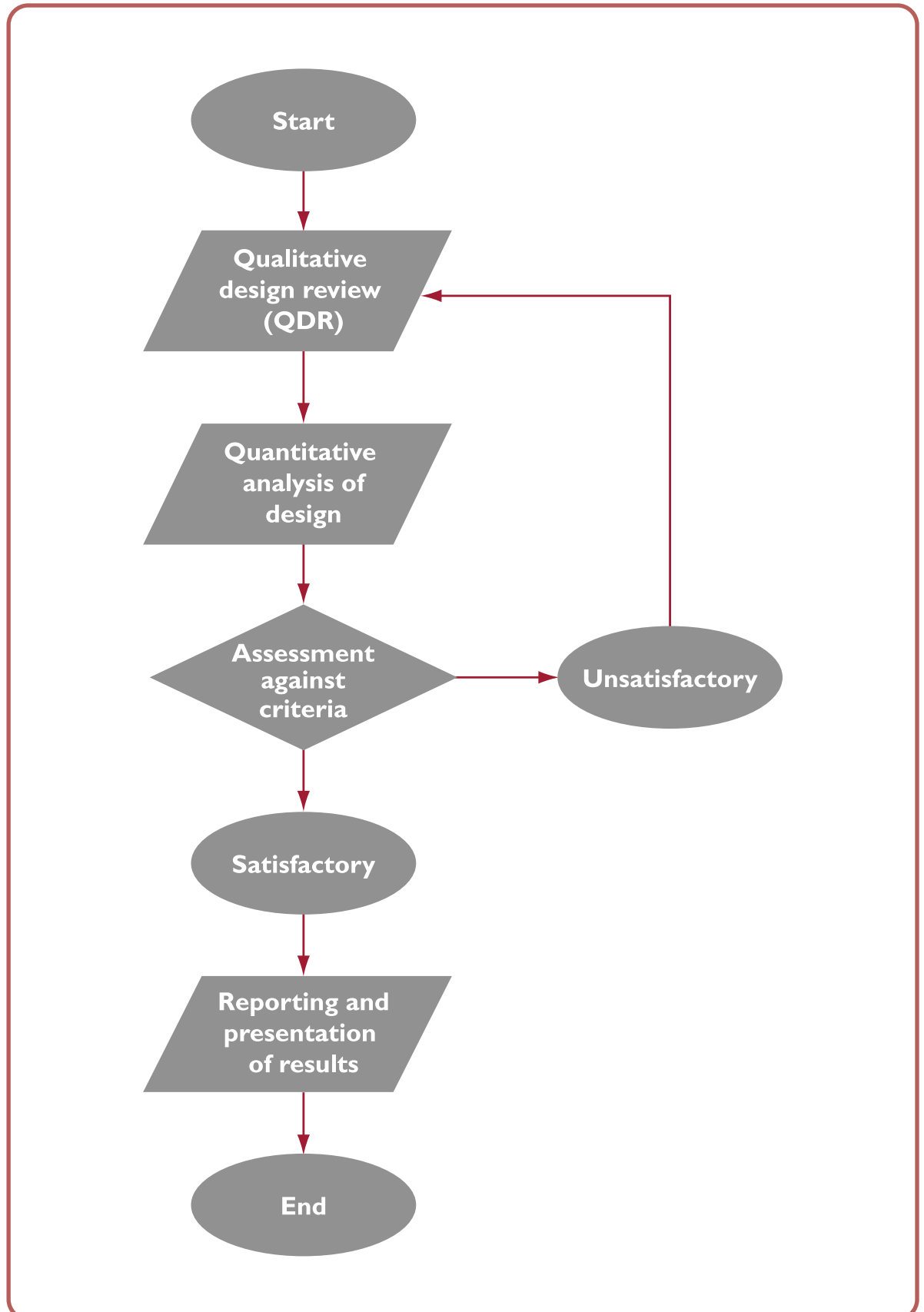

Figure 15. Structure of fire engineering methodology given in BS 7974

8.1 Qualitative Design Review (QDR)

The Qualitative Design Review is intended to establish the scope and objectives of the fire safety study, identify fire scenarios, establish performance criteria and evaluate one or more potential design solutions. Key information is also gathered to enable evaluation of the design solutions in the quantitative analysis.

8.2 Quantitative analysis

During the quantitative analysis engineering methods are used to evaluate the fire scenarios and design solutions identified in the QDR. The British Standard does not provide detailed technical guidance on the fire engineering parameters but a series of Published Documents (PDs) are available that give technical information in support of the standard.

Using the appropriate PDs the quantitative analysis can use time-based, steady state, limit state or probabilistic risk analysis to determine the impact of the fire on people and property at different stages of development.

The PD's provide selected guidance on the underlying principles and the type of calculations that may form part of a fire engineering study. However, it should be noted that the use of data and calculation procedures from other sources is not precluded and may often be essential to reach a solution.

The Published Documents that support BS 7974 are as follows:

- PD 0: Guide to design framework and fire safety engineering procedures
- PD 1: Initiation and development of fire within the enclosure of origin;
- PD 2: Spread of smoke and toxic gases within and beyond the enclosure of origin;
- PD 3: Structural response and fire spread beyond the enclosure of fire origin;
- PD 4: Detection, activation and suppression;
- PD 5: Fire service intervention;
- PD 6: Human Factors;
- PD 7: Probabilistic risk assessment.

8.3 Assessment against criteria

Following the fire engineering analysis the results need to be compared with the acceptance criteria identified during the QDR.

If none of the trial designs satisfies the specified acceptance criteria, the QDR and quantification process should be repeated until a fire safety strategy has been found that satisfies the design criteria.

8.4 Fire safety engineering and the external building envelope

At the start of the fire engineering process it is essential to clearly establish the fire safety design objectives. Typical fire safety objectives may include:

- protection of life (including firefighters);
- limitation of direct damage to property;
- minimisation of business disruption.

When the fire safety objectives have been agreed, specific performance criteria need to be established.

8 General information and regulatory requirements

Fire safety engineering

In the context of materials used in the external building envelope the achievement of these objectives may be influenced by:

- a) flame spread characteristics of internal and external faces;
- b) through fixing of cladding and detailing of panel joints;
- c) detailing of the junction between construction elements (e.g. roof/wall)
- d) material heat release rate and potential contribution to a developed fire;
- e) smoke production and potential for spread to adjacent rooms or compartments;
- f) potential for fire spread around compartment walls or floors;
- g) fire resistance of the cladding system and the supporting structure;
- h) general building fire protection measures (e.g. sprinklers).

The extent to which the above factors may influence the specification in any particular building needs to be considered in the context of the specific case.

The detailed application of fire safety engineering techniques is beyond the scope of this design guide. The general approach to fire safety engineering is illustrated by the following examples.

8.4.1 Single storey warehouse

Occupant safety

Experience suggests that fires in single storey warehouses and industrial buildings do not present a high risk to life. This is largely because the occupants are generally familiar with their surroundings, they are likely to participate in regular fire drills and are low in number. Consequently once warning of fire is given evacuation can be quickly achieved.

The main life safety concern in this type of building is to ensure that early warning of a fire is provided and that the rate of fire and smoke spread in the early stages of fire does not impede escape.

In the context of external cladding the main aim is to ensure that exposed internal surfaces do not accelerate the rate of fire spread in such a manner that escape could be impeded. The smoke production, fire resistance and the ultimate rate of heat release are unlikely to be significant when compared to the effects of a fire involving combustible warehouse contents.

Therefore if the building is located well away from adjacent buildings (or site boundaries) it may only be necessary to consider the surface flame spread properties of the faces of an external cladding system.

In the early (evacuation) stages of a warehouse fire the combustible core of an insulated panel is unlikely to contribute to the rate of flame spread if:

- a) steel facings are provided and these are fixed through to the structure using steel fixings;
- b) inter-panel joints remain tight.

Fire fighting

Whilst the occupants should be able to quickly escape, fire fighters may be put at risk if fire spread or structural collapse occurs more quickly than might be expected in other buildings. It is therefore desirable to ensure that all facings of composite panels are well secured and jointed to avoid the falling of facings and exposure of any underlying combustible material. Additionally if thermosetting core materials are utilised (e.g. PUR, PIR or Phenolic) the danger of molten flaming droplets being released is avoided.

Loss control

Where the objective is to protect the contents of the building and reduce the potential for business disruption the most effective fire protection measures are likely to be the sub-division of the building into fire resisting compartments and/or the provision of sprinklers.

In an unsprinklered warehouse building the main influence on the speed of development of a fire will be the stored combustible materials.

However, it is important to ensure that the internal linings do not accelerate the spread of fire and that combustible core materials do not enable fire to by-pass compartment boundaries.

At junctions with compartment walls or floors consideration should be given to the incorporation of non-combustible materials. In all cases and especially where combustible core materials are utilised the design of detailing and the use of metal closures should ensure that the core material does not promote fire spread around the edges of compartment walls, floors or penetrations.

8.4.2 Hospital

At the other extreme of the spectrum is the design for fire safety in multi storey hospitals. Hospitals pose particular evacuation problems because of the difficulties in evacuating patients who may be confined to bed. (See Section 5 Fire precautions in Hospitals).

Consequently the design for fire safety in hospital buildings is based upon the principle of progressive horizontal evacuation. This process involves the movement of patients away from the fire-affected area to separate fire compartments. Bed patients outside of the fire-affected compartment are expected to remain where they are and be safe from the effects of fire. It is therefore imperative to ensure that both fire and smoke will not spread from one compartment to another.

In this situation it is essential to consider all of the factors affecting the fire performance of the external cladding (8.4a to 8.4g on previous page) including the potential for fire spread, smoke production and smoke spread between compartments.

PART 2

Understanding how insulated panels react in fire

Part 2 of the EPIC Fire Guide looks at the performance in fire of Insulated Panels:-

- **To satisfy the Regulatory Requirements (See Part 1 – section 2)**
- **To satisfy the requirements of the Insurance Companies**
- **In a real fire scenario through the analysis of Case Studies**

EPIC has conducted or commissioned the majority of the major research studies into the performance of Insulated Panels in fire through small and large scale tests and also extensive research into major fires and specifically where Insulated Panels may have been used in the construction.

This Part of the Guide should be of particular interest to building designers, Insurance Companies, Fire Services and other building professionals who wish to have a detailed appreciation of the way Insulated Panels actually perform.

9 Understanding how insulated panels react in fire Tests to meet Regulatory requirements

Fire testing in relation to the regulations is relatively small scale and only gives an indication of the way a product may perform in fire and a comparison of the relative ranking of various products.

The fire performance of insulated panels is influenced by the nature of the protective facings, the design of the panel joints and the detailing at junctions. It is only possible to determine the likely practical performance by considering the insulated panel system under realistic large scale testing (see Section 11).

This section briefly describes the fire tests relevant to insulated panels. The relationship between the British Standard and the new European Harmonised classifications is summarized in Section 3 – Tables 2 and 3.

In assessing the performance of panel systems various fire test procedures are available. These are generally divided into two main categories:

- a) reaction to fire tests;
- b) fire resistance tests.

9.1 Reaction to fire tests

These are small scale tests designed to check the performance of Insulated Panels in terms of the surface properties and integrity i.e. flame spread, heat contribution and no penetration particularly at joints. The test is normally carried out on the internal face but both faces can be tested if required, for example when a Panel is to be used internally.

In the European standardised tests classification is in accordance with BS EN 13501-1 and in the British Standard test in terms of performance in Tests BS 476: Part 7 and BS476: Part 6. Insulated Panels achieve Euroclass B, or Class 0 to BS 476 Parts 6 & 7, which is within the requirements.

9.2 External Fire Performance – Roofs

This is a small scale test designed to check surface spread of flame and penetration of fire from for example a burning brand falling on the roof.

In the European test classification is in accordance with BS EN 13501-5 (ENV 1187 Method 4) and in the British Standard test the performance is measured in BS 476: Part 3. Insulated Panels achieve Euroclass B_{roof}(t4) or class AA or AB to BS 476 Part 3), which is within the requirements.

9.3 Fire Resistance – see section 3.3.2

Where required Insulated Panels can be tested to illustrate their capability to meet certain fire resistance criteria set out in the Regulations to prevent fire spread between buildings or compartments i.e. for walls on or close to a boundary or fire escape route and also for use as compartment walls.

In the European standardised test classification is in accordance with EN 13501-2[20]. The European harmonised test is fundamentally similar to the British Standard BS 476 Part 20[21] & Part 22 tests. These are well tried and proven tests and Insulated Panels are classified in terms of their performance in minutes – 15, 30, 45 etc.

Fire resistance ratings are specific to each panel type and are dependent upon the joint design, formulation of the PIR or MW core material and the thickness of the panel being tested.

10 Understanding how insulated panels react in fire

Large Scale Tests

10.1 Insurance Industry tests

Whilst the small scale Reaction to Fire tests above (9.1 and 9.2) have a proven track record to show that materials meet the regulatory requirements, they only test a small sample of product and therefore are ineffective in identifying the likely performance in a large scale fire and potential failures in any joints.

Over the past 30 years the major insurance organisations (Loss Prevention Certification Board (LPCB) and FM Global (FM)) – see Section 7, have developed their own test procedures on a larger scale, with enhanced heat sources that are intended to establish the performance in fire of Insulated Panels, particularly during the development phase of a fire.

The LPS 1181 test consists of a room that measures 10 m x 4.5 m x 3 m high (Figure 16) and most importantly assesses panels as they are installed in practice. A heat source comprising a 35kg timber crib to simulate a real fire is placed in the corner of the building (Figure 17) and the room configuration gives rise to a severe test generating 510 KW over the period of the test with a maximum heat output of around 1MW. The crib is placed adjacent to a panel joint. Experience has shown that this configuration seriously challenges the panel and the panel jointing system.

Panels receive an LPS Certification providing that the flame spread is limited and there is no flashover within the compartment.

The corresponding FM Approvals testing regime includes a number of tests outlined in Section 7 on page 34. Tests range from small scale laboratory based tests to larger room and room corner tests.



Figure 16. Fully instrumented test building



Figure 17. Observation and recording

10.2 Information from large scale tests

EPIC has supported the view of the Insurance Companies and Fire Services that a large scale and more challenging test is essential to give a better indication of the way Insulated Panels may perform in an actual fire.

In 1999/2000 EPIC conducted one of Europe's largest fire research programmes [22] using the LPS 1181 test to determine the fire performance of a range of panels and also other comparable cladding systems. Warrington Fire Research carried out the tests and the research programme was conducted by Arup Fire. A summary of the tests and the results can be viewed on www.epic.uk.com/fire_tests.jsp

The benefits of the LPS 1181 test are that the configuration allows the metal faced Insulated Panels to be firmly fixed to the supporting framework, as in practice, and for the engineered joints to perform as designed to protect the core material and provide low air permeability. After the tests the panels can be easily demounted and inspected.

These large scale tests give a good indication how Insulated Panels may perform in the developing stage of a fire. The most relevant tests in the EPIC/Arup programme were those with PIR (polyisocyanurate) and MW (Mineral Wool) lamella cores that meet the Insurance Industry certification requirements. All Insulated Panels produced in the UK since 2004 are of this type.

The principle features, which have been confirmed by the analysis of actual fires, are as follows.

- Structural integrity of the external roof and wall panels and the fixings hold the panels in place
- The core is primarily affected by heat conduction. There is minor buckling at the internal joints and some flame impingement on the core material. There is no instant heat release or significant contribution to the fire source
- Externally the joints are unaffected and there is no smoke release through the joints
- There is no hidden flaming or fire spread down the cores of the panels and any minor flaming at the joints extinguishes as the fire source dies down

Understanding how insulated panels react in fire

Fire Research and Fire Case Studies

11.1 Fire research

A major programme to better understand the influences behind major fires was initiated by EPIC in the 1990s as a result of a number of fires in the food industry. This study conducted by EPIC was the first major study of its kind specifically analysing fires and the associated type of construction. The research studied over 400 major fires in the industrial and commercial sector with a loss of more than £500,000 during the period 1992 – 2001.

The Research highlighted a number of important features.

- 80% of major fires were associated with high internal fire loads of the contents
- Contents such as chemicals, plastics, paper, furniture, fabrics, rubber and timber are likely to result in a total/major loss
- Major losses are independent of the type of construction
- 97% of major fires were in buildings constructed with 'traditional materials' – brick, metal cladding, asbestos cladding, slate etc
- 3% involved rigid urethane constructions against an estimated 15% of building stock in these sectors
- Whereas 13% (equivalent to 27% of monetary loss) of the fires involved panels with polystyrene cores used internally

Real fires history 1992-2001: Industrial and commercial buildings.

(Source EPIC/FPA Records + 500K Loss).

Analysis by number of fires	No.
Traditional – Brick – Metal systems with mineral fibre insulation	150
Polystyrene sandwich panel systems	23
PUR/PIR external cladding	6
Total fires	179

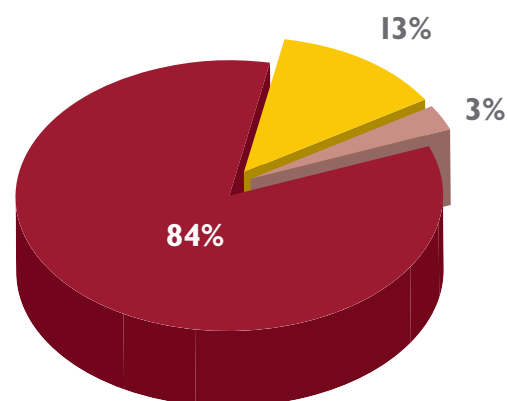

11.2 Case Studies

Sections 9 and 10 illustrate the type and extent of the information that can be obtained from small to large scale fire tests.

In particular the performance in the LPS 1181 tests has been proven to give a good idea of likely performance in the developing stages of a fire. The LPS 1181 large scale fire tests indicate good structural integrity and low contribution from Certificated PIR (and MWV) cored Insulated Panels.

However all fire situations are different and this was highlighted by the research described in Section 11.1. It was noted that the contents of the building, the fire load of the contents, and their proximity to the walls have a significant bearing to the development and outcome of the fire.

The final part of the research programme into the performance of Insulated Panels in fire was to check the indicated performance against actual fires. To achieve this link EPIC and EPIC member companies, supported by Tenos Fire Consultants, conducted a series of studies into actual fires in which PIR cored insulated panels had become involved.

The following case histories analyse the performance of rigid urethane insulated panels in actual building fires and clearly illustrate that PIR cored Insulated Panels perform well in actual fire scenarios.

Case Studies A-C focus on whether there was any fire spread or significant contribution to the fire and assesses the performance of panels either side of a fire resisting compartment wall.

- Study A: Clifton Comprehensive School
- Study B: R A Wood Adhesive tapes
- Study C: Suffolk Food Hall

Case Studies D-F analyse the performance of panels from external fire attack.

- Study A: Wharfedale Hospital
- Study E: Spider Transport
- Study F: Eagle Global Logistics

The advanced formulations of the PIR insulation cores of Certificated Panels give significantly improved performance over the PUR cores of pre-2004 panels in terms of higher temperature before any involvement; extensive formation of protective char; and low smoke generation.

Understanding how insulated panels react in fire

Fire Research and Fire Case Studies

Summary

School – roof application
PIR cored Insulated Panels

Fire

- High fire load – paint and solvents
- Local and intense

Observation

- Minimal contribution of core to fire
- No fire spread within panels
- No fire spread across fire stop partition



11.2.1 Case study A

Clifton Comprehensive School (July 2004)

Location: Rotherham

Building description

The area associated with the fire was part of a development at the school nearing completion at the time of the incident. A passageway had been constructed to provide an escape corridor between the two flat roofs. The floor of the passageway was of concrete slab construction. Blockwork walls, that formed the corridors on the ground and first floors, had been carried to 1370mm above the concrete slab of the passageway thereby forming the lower walls of the passageway.

The upper walls of the passageway consisted of partitioning between the top of the blockwork walls and the underside of the insulated roof panels. The partitioning was constructed using a 70mm stud partition system consisting of metal studding fixed to the top of the blockwork wall. The top of the vertical studding terminated in an inverted 'U' channel that ran the full length of the roof. Fire resisting board, approximately 25mm thick, had been installed between the top of the inverted 'U' channel and the underside of the insulated roof panels.

The roof was constructed using insulated roof panels with a core of PIR (polyisocyanurate) approved to LPS 1181 Part 1. The insulated roof panels had not been cut into and the panels passed over the top of the partition system. Each side of the partition system had been clad with fire resisting board, approximately 15mm thick.

Fire

The fire was reported at 19.37 hrs when smoke was seen to be coming from the centre of the new roof section. From subsequent investigation it was believed that the fire occurred in a drum of roof sealant containing solvents that was accidentally or purposely ignited with a naked flame. The roof sealant was both the material first ignited; and the material mainly responsible for development of the fire.

The fire burned fiercely with flames impinging on the left hand blockwork wall, the partition and Insulated Panels above. Flame and hot smoke traveled down the passageway at high level in both directions.

The deformation of the purlins immediately above the seat of the fire shows that this was a very hot fire. The internal faces of eight roof panels in the immediate area of the fire had delaminated and deformed, exposing the insulation.

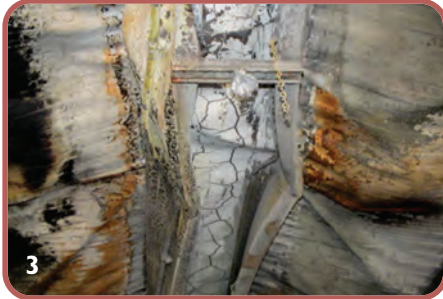

Observation

In spite of the substantial quantity of insulation exposed, there was no evidence that the insulation contributed to the spread of this fire; although it is probable that, while the fire was burning, the insulation charred and some smoke would have been produced.

From the physical evidence of the limited spread of heat and smoke to the roof void to the west of the passageway, it is clear that the general construction of the passageway and the partition system worked effectively as fire resisting barriers. There was only limited spread of heat and smoke between the top of the partition and the underside of the Insulated Panels. There was no evidence of heat or smoke spread through the insulation of the Insulated Panels.

Comment

The Insulated Roof Panels did not contribute to the cause of this fire. There was no significant involvement from the core material and no fire spread within the core despite exposure to the fire.

Understanding how insulated panels react in fire

Fire Research and Fire Case Studies

Summary

Factory – roof application
across compartment wall

PIR cored Insulated Panels

Fire

- High fire load – plastics, adhesives & solvents
- Major fire leading to collapse of structure

Observation

- Extensive charring of core
- No fire spread through core
- No fire spread round panel over compartment wall
- Integrity maintained over compartment wall
- Satisfies AD-B requirement as an ‘alternative’ construction over compartment wall

11.2.2 Case study B

RA Wood Adhesive Tapes (November 2009)

Location: Cannock, Staffordshire

Building description

The main building consisted of a steel frame with the lower part of the external walls and interior walls constructed of blockwork

The production area of the RA Wood Adhesive Tapes tenancy was separated from the two storey office and welfare facilities accommodation by nominally 30 minute fire resisting construction; and from the adjoining tenancy by a compartment party wall of two leaves of 200mm blockwork encapsulating the vertical portal frame stanchions for the full height of the building.

The upper parts of the external walls and roof comprised Insulated Panels with a core of PIR (Polyisocyanurate) approved to LPS 1181 Part 1 Grade EXT-B.

The head of the party compartment wall was fire stopped to the underside of the Insulated Roof Panels over-sailing the wall using sand cement mortar.

It is understood that the Insulated Roof Panels did not incorporate a band of limited combustibility material providing a break in the PIR core of the panel at the point where the panels over-sailed the party compartment wall. At the time that the building was constructed, this was a recommendation in clause 9.29 of Approved Document B (2000 edition) and in the current 2006 edition of Approved Document B the recommendation (now in clause 8.30) refers to the width of this band being 300mm.^(*)

* Advisory guidance note: Building Regulations Fire Safety (Part B) – Buildings other than Dwelling Houses FAQs www.planningportal.gov.uk/buildingregulations/approveddocuments/partb/faqs/other

“However, an alternative approach might be to use a panel system which has been shown in a large scale test to resist internal and external surface flaming and concealed burning.”

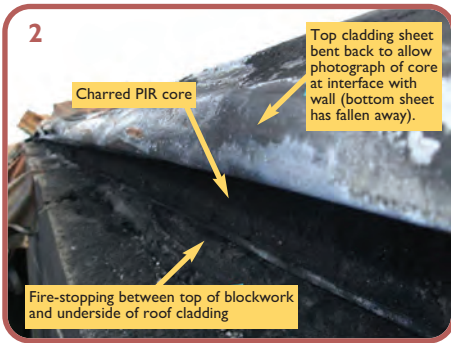

Fire

From statements made it is understood that the fire started with a suspected ignition event involved a high level light fitting towards the northeast corner of the production area. This was a large fire requiring attendance by 60 fire service personnel. The intensity of the fire resulted in the penetration of fire through the roof and flaming well above the height of the building. The report at the time stated that the Fire Service took the decision to allow the fire to burn out and to carry out appropriate procedures to prevent spread of fire to adjacent buildings. It is understood that the fire burned through into the following morning before reducing to an intensity at which fire-fighters were able to extinguish the fire.

Photograph 1 taken from an aerial platform position to the south side of the building and looking along the line of the compartment wall separating the RA Wood Adhesive Tapes (to the west) and Joinery company (to the east) illustrates how the fire completely destroyed the roof structure to the left whilst the roof over the adjacent joinery company is still in place.

The complete collapse of steel supporting structure shown in the photograph, and the presence of melted aluminium from door controls indicates that global temperatures attained in the production area compartment were significantly in excess of 650°C. The reported fire duration and evidence of the temperatures achieved indicate that the overall fire exposure of the wall separating the production areas of the two tenancies was at least equivalent to a 60 minute fire resistance test.

Photograph 2 shows shows the charred PIR core of the roof cladding where the PIR core remained in place to the center of the blockwork leaf on the RA Wood Adhesive Tapes side of the party wall.

Photograph 3 was taken from inside the adjacent joinery company looking up at the underside of the roof cladding along the party wall line.

There was smoke leakage into their premises and this was also evidenced by the striations of smoke staining on the roof soffit and local loss of the plastisol coating to the steel skin close to the apex. However, it was clear from the inspection that there was no loss of fire compartmentation provided by the party wall and the fire did not spread to the adjoining tenancy.

The roof cladding over the adjacent joinery company remained sufficiently intact to provide continued weather protection and to allow that business to resume operations shortly after the fire was extinguished by the fire service.

Understanding how insulated panels react in fire

Fire Research and Fire Case Studies



11.2.2 Case study B (continued)

RA Wood Adhesive Tapes (November 2009)

Location: Cannock, Staffordshire

Comment

The following conclusions can be drawn from the site inspection:

- The fire was sufficiently intense to have subjected the party wall between the adjacent tenancies to a level of exposure equivalent to at least 60 minutes in a standard fire resistance test.
- The fire compartmentation provided by the party wall prevented fire spread to the adjacent premises.
- The charring exhibited by the PIR core material indicated the formation of a sufficiently stable char within the panel to provide an effective fire stop between the steel skins of the cladding at the head of the compartment party wall.
- The omission of a band of material of limited combustibility in the composite roof panel at the point of intersection with the head of the party wall (as recommended by Approved Document B guidance) did not result in a break-down of fire compartmentation and clearly shows that PIR insulated Panels may be considered as 'an alternative approach' under the requirements of the AD-B.
- The findings of the site inspection provides evidence that the use of a LPS 1181 Grade EXT-B certificated Insulated Panel with PIR core can provide sufficient resistance to fire propagation and erosion such that the functional requirement of the Building Regulations (Regulation B3) can be satisfied without providing a 300mm wide band of limited combustibility material to replace the PIR core where Insulated Panel passes over a compartment wall – see advisory note above. (i.e. it is not necessary to adopt the recommendation of clause 8.30 of Approved Document B).

Summary

Abstract

Converted Farm Building –
Retail

PIR cored Insulated Panels
Internal fire attack from
plant fire

Observation

- Local charring of the core
- No fire spread through the PIR core
- Integrity maintained – no promotion of fire spread

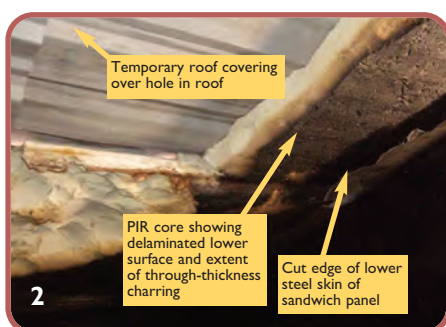

11.2.3 Case study C

Suffolk Food Hall (January 2010)

Location: **Wherstead, Ipswich, Suffolk**

Building description

The building was a converted farm building comprising a timber frame construction with PIR cored insulated roof panels approved by LPCB to LPS 1181 Part 1 Grade EXT-B. The walls were a metal clad built-up system with glass fibre insulation.

Fire

The fire occurred in the building services/M&E mezzanine area directly under the roof and involved the combustible services and the timber construction in the area. Based on the charring rate of timber the depth of charring indicated an exposure of the panels equivalent to between 20 and 25 minutes in a fire resistance test.

Photograph 1 shows the extent of charring to the timber at the seat of the fire and the relationship to the panels. Photograph 2 shows a cross-section where the panel has been cut away and illustrates only partial internal charring of the PIR core with the majority of the core unaffected.

Comment

The following conclusions can be drawn from the site inspection:

- The fire was sufficiently intense to have subjected the roof membrane and wall separating the plant area from the retail space to a level of exposure equivalent to approximately 20-25 minutes in a standard fire resistance test.
- Fire did not spread from the mezzanine plant area to the rest of the building.
- The PIR core material of the roof sandwich panels did not transmit fire from one side of the walls enclosing the plant area to the other.
- There was no fire spread within the PIR core

Understanding how insulated panels react in fire

Fire Research and Fire Case Studies

Summary

Hospital – wall application
PIR cored Insulated Panels

Fire

External façade fire
High fire load – paint and
bulding materials

Observation

- No ignition or involvement from PIR core
- No fire spread within core
- No promotion of fire spread

11.2.4 Case study D

Wharfdale Hospital (July 2003)

Location: Silsden, West Yorkshire

Building description

The building consisted of three storeys constructed around a quadrangle. A two-storey section bisected the quadrangle to form a triangular piece of land at ground floor level.

The building had a steel frame and all floors were concrete, the upper two concrete floors being on steel decking. The first and second floors were clad with 70mm thick PIR Insulated Panels approved by LPCB to LPS 1181 Part 1 2003 as Grade EXT-B. At the time of the fire, the ground floor had a steel framework in place for cladding but no cladding had been fixed. All steel beams had been coated with an intumescent paint to give a standard of fire resistance of one hour.

Fire

The premises were still under construction when the fire occurred. At the date of the fire the ground floor was in use as a storage area for building materials. The fire occurred in stored materials (plastics and paints) in the open ground floor of one section of the building. Damage was caused to the steel beams that supported the first floor, the profiled steel sheets that rested on the beams and the concrete floor that had been laid on the profiled steel sheets.

The intensity of the fire was such that it had removed the intumescent coating to the beams supporting the first floor. Although rated to provide a one-hour standard of fire resistance the intumescent coating resisted the fire for less than half an hour in this fire. The beams had distorted and the concrete floor at first floor level had dipped above the fire. The expansion of the beams had pushed out the supporting columns. The concrete floor above had cracked due to the movement of the beams.

The fire played up the external facing of the building, affecting the panels on the first and second floors.

Observations

- There was no fire spread to the upper floors
- There was damage to the external skin of the cladding to the upper floors but no spread in the insulation of the wall panels and no fire spread to the eaves
- The exterior facing of the panels to the first and second floors was damaged by heat and smoke

Comments

In spite of the significant heat generated by this fire (sufficient to damage the intumescent coating and distort the steel beams); the orientation of the cladding panels (directly above the fire); and the fact that fire stopping was not in place; the cores of the panels, did not ignite, did not promote fire spread within the core or to the eaves and did not significantly contribute to the products of combustion. The panels on this project are approved by LPCB to LPS 1181 Part 1 2003 as Grade EXT-B.



Summary

Distribution warehouse application
PIR cored Insulated Panels

Fire

- External fire – arson
- Lorry fire

Observation

- No contribution from panels
- No penetration into building
- No fire spread within panels

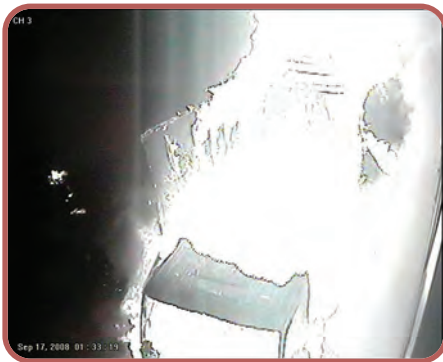

'Explosion' of debris from both sides and top of vehicle – fireball projected onto building cladding.



11.2.5 Case study E

Spider Transport (September 2008)

Location: Rathnew, Wicklow, Republic of Ireland

Building description

The building was used as a warehouse and distribution centre, and is constructed of a steel frame with brickwork lower walls and Insulated Panels with a PIR core, approved to LPS 1181 Part 1 Grade EXT-B, installed as the upper wall cladding.

Of particular note is that there is a design gap between the drip flashing and the bottom edge of the Insulated Panels. This gap above the drip flashing coupled with the corrugated profile of the Insulated Panels meant that the bottom of the insulating core of the Insulated Panels was exposed to any flame impingement on that part of the blockwork wall and the cladding above.

There was also a similar gap above the up-and-over door between the head flashing and the bottom edge of the Insulated Panels.

Fire

A truck had been parked across the two main "up and over" doors of the building to prevent unauthorised access during the night. Arsonists set the cab on fire and this quickly spread throughout the vehicle. The intensity of the fire and the proximity of the truck to the building meant that the panels were soon exposed to what is referred to in the investigation report as "prolonged flame impingement" during the 25 minutes before the fire brigade arrived (the isolated location meant that the alarm was not raised until 15 minutes after the fire started). At one stage there was also an explosion and a fireball projected onto the panel facing as conditions worsened.

Understanding how insulated panels react in fire

Fire Research and Fire Case Studies



11.2.5 Case study E (continued)

Spider Transport (September 2008)

Location: Rathnew, Wicklow, Republic of Ireland

Observations

An examination of the Insulated Panels both above and at the sides of the up and over doors showed the outer and inner skins to be intact with no deformation. In fact it was extremely difficult to prise open the outer skins to examine the inner core.

The lower edges of the Insulated Panels immediately above the up and over door on the right were prised open. The inner core had charred but had remained in-situ and there was no evidence of deformation or delamination. In addition, there was no evidence that the core of the Insulated Panels had assisted fire spread.

The proprietary wallboard at the right side of the up and over door (adjacent to where the front of the vehicle had been) had cracked as a result of heat. However, even at this location the outer and inner skins of the Insulated Panels were found to be intact with no deformation.

The lower edges of the Insulated Panels, immediately above where the proprietary wallboard had cracked with the heat, were prised open. The inner core had charred only at the edge nearest the roller-shutter door. The core had remained in-situ and there was no evidence of deformation or delamination. In addition, there was no evidence that the core of the Insulated Panels had assisted fire spread.

Comment

Key considerations were whether the panels contributed in any way to the spread of the fire and whether they helped prevent fire entering the building.

The report concluded that there were no signs of any spread of heat through the panel core, or that the panels contributed to the damage caused by the fire in any way. Furthermore, there was no delamination of the metal panel lining and the insulation core stayed in place, important points in maintaining system integrity and fire resistance

Despite the ferocity of the fire, the inside of the premises was unaffected and business resumed as normal the next day.

Summary

Abstract

Distribution warehouse application
PIR cored Insulated Panels
External fire attack from adjacent burning building

Observation

- Paint coating burnt off on adjacent walls
- No ignition of PIR core
- No flames or smoke entered the building

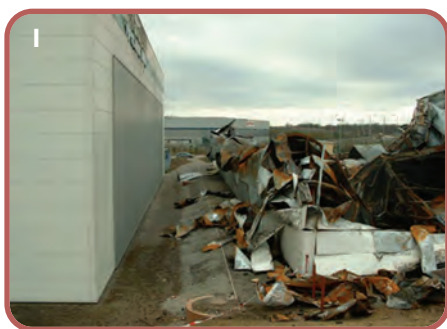

11.2.6 Case study F

Eagle Global Logistics (January 2005)

Location: Thurrock, Essex

Building description

The building was one of a pair of logistic warehouses with a separation distance of 8.7 m. These were conventional steel frame buildings clad with PIR cored insulated panels approved by LPCB to LPS1181 Part 1 Grade EXT-B on the walls and a built-up metal clad roof system with glass fibre insulation.

Fire

The devastating fire in one of the pair was sufficiently intense to result in collapse and the building was completely burnt out. The fire Consultant's assessment report stated that the insulated panels did not contribute to the spread of fire and the cores only burnt when exposed to direct intense flame attack.

In the second building the LPCB approved panels which were only 8.7 metres from the burnt out unit, played a significant role in preventing fire spread to an adjacent building. The severe heat and flames generated by the burning building were so intense that the paint coating on the PIR cored insulated panels on part of the next-door building was burnt off but the PIR core did not ignite and no flames or smoke entered the adjoining building.

Comment

In spite of the intense heat sufficient to collapse the building there was no evidence to suggest that the panels contributed to the spread of the fire within the building. Neither is there any evidence that the fire spread through the cores of the panels.

Appendix: Management of fire safety

This appendix refers equally to all forms of roof and wall cladding and not specifically to insulated panels. It covers the management of fire safety both during construction and maintenance operations and as part of the day-to-day operation of the building.

Statistics suggest that 70% of all major fires occur as a result of poor management and maintenance rather than as a result of inadequate design or the nature of the processes carried out within buildings.

Risk assessments may have been made at the planning stages of a building and if so will have covered its operation and use and also any foreseen maintenance activities relating to the equipment or fabric of the building. Against this background, this appendix highlights specific maintenance and construction issues that are known to have been the cause of a number of significant fires.

The subjects detailed in this section are part of a wider inspection programme recommended by the insurance companies and which is set out in full on the 'Self Inspection forms for Commercial/Industrial Premises' available from those companies.

Generally the nature of the external cladding, including insulated panels with the most commonly used rigid urethane and mineral fibre cores, will not have a significant effect on the likelihood of a fire starting. However, the specific procedures highlighted in this section are advisable where combustible insulation is utilised.

The role of fire safety management

It is essential that any person who is responsible for the operation of a building should implement procedures to prevent a fire occurring and minimise its effects in the event that these procedures are not successful. Ideally such procedures, and details of the buildings construction and fire safety systems should be documented in a fire safety manual. This manual might typically include the following items:

- a) fire safety policy statement;
- b) safety management structure and responsibilities;
- c) details of building construction relevant to fire safety;
- d) actions to be taken in a fire emergency;
- e) fire drills and staff training;
- f) housekeeping (e.g. removal of combustible waste);
- g) planned maintenance of fire safety measures;
- h) safety procedures for hot works and other maintenance;
- i) security (to combat arson);
- j) contingency plans for salvage and damage control;
- k) record keeping;
- l) procedures for updating manual and auditing its implementation.

Good fire safety management can be a key factor in minimising the risk of fire in buildings. Detailed guidance on management procedures for fire safety will be given in a forthcoming part of BS 5588 [20], which is currently in the course of preparation.

Hot works

Hot work is work that involves open flames or sparks or any other activity that generates heat. Fires involving hot work have led to multi-million pound losses. Most frequently the cause is carelessness and ineffective supervision while hot work operations are being carried out.

The sources of heat most commonly involved which may be used in conjunction with or in close proximity to roof and wall cladding systems include:

- gas and electric welding and cutting equipment
- blowlamps and blowtorches
- grinding wheels and cutting discs

Hot working should be avoided whenever possible, but when making structural changes to a steel framed building or when installing or modifying steel pipe work, cutting, grinding and welding appropriate precautions should be taken.

During hot works and cutting operations it is recommended that any exposed combustible cores are protected by temporary coverings.

Such coverings and screens need to be manufactured from non-combustible or non-flammable materials. Welding blankets are the preferred solution for protecting all exposed surfaces, including ends or edges of panels. Preferably no hot work should be carried out in the immediate vicinity of any exposed insulant of whatever type. Low flame spread plastic coverings, which are intended to prevent damage to finished items during construction do not provide the required levels of protection to resist welding or cutting sparks or splatter.

All works should be properly supervised and a full inspection carried out on completion. Personnel engaged to carry out this work should be competent and fire extinguishers should be on hand at all times.

Experience has shown that a satisfactory standard of care is far more likely to be achieved where a formalised permit to work – a 'Hot Works Permit' – is in force, issued under the supervision of an experienced person who has the authority to ensure compliance with the procedures.

A typical Hot Works Permit:

- specifies the particular job to be carried out
- lists any special conditions
- specifies the area where the work is to be done
- is issued for a set time period.

Follow-up checking:

A fire watch should continue for at least one hour after work is completed, to detect and extinguish any incipient burning in the work area and in all adjoining areas to which sparks and heat may spread. These could include floors above and below and areas on the other side of walls to where the work is being carried out.

Appendix: Management of fire safety

Cutting panels

Neither hot cutting techniques nor grinding wheels should be used to cut any type of insulated panels and in particular panels incorporating combustible cores.

Panels should be cut with a powered reciprocating saw and all exposed site cut panels should be protected with a suitable edge protection lacquer.

Holes and apertures are frequently cut to take cabling and wiring through panels, particularly in the food processing and cold store industries, where polystyrene has been the common core insulation. It is essential that full inspection is carried out to ensure that:

- the work has been properly carried out and that the cabling/wiring is fully protected against chaffing and abrasion
- any holes or apertures are properly closed off according to the manufacturers instructions, including where necessary the use of fire stopping materials.

Exposed cores

Any core material of an insulated panel or any insulated cladding system that becomes exposed as a result of cutting penetrations, maintenance work or impact damage should always be protected with metal closure flashings, as soon as practical, following the panel manufacturers recommended procedures.

Rubbish/waste management

A common source of extensive fire damage is fires started, deliberately or accidentally, in skips and rubbish containers located adjacent to the external wall of a building.

Whenever practical skips and other rubbish should be kept well away from the external walls of a building. Waste in the open is particularly attractive to an arsonist and strict controls on the storage and disposal arrangements are essential.

- All waste stored in the open should be at least 10 metres from the building and a minimum of 2 metres from the perimeter fence. If this is not possible, lockable enclosed metal skips or a secure enclosed store or compound should be provided, located as far as practical from door and window openings.
- All waste should be deposited in appropriate containers or designated areas provided. These should be clearly marked and should not be under canopies or trees.
- Aerosol cans, containers of flammable liquids and gas cylinders (even if empty) should be kept separately and disposed of as directed by the local authority. They should not be placed in skips with other waste.

Internal self-inspection Reports

Self-inspection systems are recommended by insurance companies as part of an on-going programme to increase awareness of fire hazards and reduce risks. Internal Fire Inspection Reports are available which illustrate the areas that could be part of a self-inspection system.

The reports cover a much wider inspection programme than is directly relevant to the envelope cladding of a building. Examples from a typical list relating to panels and insulated cladding are:

Electrical equipment

- Is there any temporary wiring/cabbling
- Is the wiring/cabbling passing through panels correctly installed?

Gas cylinders

- Are gas cylinders stored in a secure fire safe compound outside the building?

Fork lift truck/electric vehicle charging area

- Is the charging area clean and tidy?
- Are the low voltage charging cable connectors undamaged?
- Has storage been allowed in the charging area?

Hot work

- Have hot work permits been used as required?

Waste management/rubbish

- Are all idle pallets and waste skips at least 6 metres clear of buildings?

Fire safety during construction

A large proportion of all fires occur when buildings are being constructed, modified or extended.

The Health and Safety at Work Act 1974 is applicable to all work carried out during the construction phase. Under this act the employer has a duty to keep the workplace in a safe condition without causing risk to health. The Act is enforceable by the Health and Safety Executive.

Guidance in respect of construction, including alterations and extensions is given in: “Fire Prevention on Construction Sites” published by the Fire Protection Association [23]; and “Fire Safety in Construction Work” published by the Health and Safety Executive [24].

Where temporary buildings are introduced within, or adjacent to the building envelope, only those site buildings that comply with the LPS 1195 standard should be used.

The procedures recommended for hot work above should be implemented.

References

- [1] Amendment to Building Regulations – Approved Document L2: 2010 edition.
- [2] Approved Document B: Fire Safety. The Building Regulations 2010. Department for Communities and Local Government. HMSO 2010.
- [3] Building (Scotland) Regulations 2004 as amended. Technical Handbook Section 2. Scottish Executive.
- [4] Technical booklet E – Fire Safety. The Building Regulations (Northern Ireland) 2001. Department of the Environment for Northern Ireland. HMSO 2001.
- [5] England and Wales: The Regulatory Reform (Fire Safety) Order 2005. Department for Communities and Local Government. HMSO 2005.
- [6] BS 476: Part 7: 1987: Fire tests on building materials and structures. Method of classification of the surface spread of flame of products.
- [7] BS 476: Part 6: 1989: Fire tests on building materials and structures. Method of test for fire propagation for products.
- [8] BS EN 13501-1 Fire classification of construction products and building elements – Part 1: Classification using test data from reaction to fire tests
- [9] BS 476: Part 22: 1987: Fire tests on building materials and structures. Methods for determining the fire resistance of non-loadbearing elements of construction.
- [10] BS 476: Part 3: 2004: Fire tests on building materials and structures. External fire exposure roof tests.
- [11] BS EN 13501-5 Fire classification of construction products and building elements – Part 5: Classification using test data from external fire exposure roof tests
- [12] External fire spread: building separation and boundary distances. BRE report BR 187. 1991.
- [13] BS 476: Part 4: 1970: Fire tests on building materials and structures. Non-combustibility test for materials.
- [14] BS 476: Part 11: 1982: Fire tests on building materials and structures. Method for assessing the heat emission from building materials
- [15] NHS Firecode – Fire precautions in new hospitals. Health Technical Memorandum HTM 05-02. NHS Estates 2009.
- [16] Building Bulletin 100 (BB100), Guidance on the application of Building Regulations in Schools
- [17] LPS 1181 Part 1 – “Requirements and Tests for Built-up Cladding and Sandwich Panel Systems for Use as the External Envelope of Buildings. Loss Prevention Council.
- [18] The LPC design guide for the fire protection of buildings. Jan 2003 Fire Protection Association.
- [19] BS 7974 Application of fire safety engineering principles to the design of buildings (2001).
- [20] BS EN 13501-2 Fire classification of construction products and building elements – Part 1: Classification using test data from fire resistance tests
- [21] BS 476: Part 20: 1987: Fire tests on building materials and structures. Methods for determining the fire resistance of elements of construction (general principles).
- [22] Performance of external cladding systems in fire. Results of Fire Research 1999 Engineered Panels in Construction [EPIC].
- [23] Fire Prevention on Construction sites: May 2009. Fire Protection Association.
- [24] Fire safety in construction work. Guidance for clients designers and those managing and carrying out construction work involving significant fire risks. HSG 168. Health and Safety Executive 1997.

EPIC was set up in 1991 to promote quality roofing and cladding systems through the use of factory-engineered panels. Insulated panels maximise thermal efficiency whilst reducing the risk and effects of condensation and significant energy loss through air leakage.

The new building regulations and today's cost competitive and quality conscious environment require that industrial and commercial buildings are high performance designs working with maximum efficiency and minimum running costs. Rigid urethane insulated panels allow designers to achieve these goals with confidence and minimum risk.

Contact EPIC 29 High Street, Ewell, Surrey KT17 1SB Telephone: 020 8786 3619 Fax: 020 8786 8887 www.epic.uk.com

Download information from the EPIC website

This guide on Fire safety and the performance of Insulated Panels in fire can be downloaded from the EPIC website at www.epic.uk.com

EPIC have also published a series of other Guides including:

- Insulated Panels, Requirements and compliance – Building Regulations: Conservation of fuel and power 2010
- Insulated Panels, The Fire Safety Order (2005)*
- Insulated Panels. Identification and disposal*

* These guides are available in hard copy form and through the website.

Acknowledgements

EPIC would like to thank the following organisation for their guidance, help and assistance in the production of this fire guide

Tenos Fire Safety Engineering
Trafford House, Chester Road
Manchester M32 0RS

THE EPIC MEMBERS ARE:

Kingspan (Insulated Panels) Limited
Greenfield Business Park No 2, Greenfield,
Holywell, Flintshire CH8 7HU
Telephone: 01352 716100 Fax: 01352 710161
info@kingspanpanels.com
www.kingspanpanels.com

A. Steadman & Son Limited
Warnell, Welton,
Carlisle CA5 7HH
Telephone: 0169 74 78277 Fax: 0169 74 78530
info@steadmans.co.uk
www.steadmans.co.uk

Panels and Profiles (Tata Steel)
Shotton Works, Deeside,
Flintshire CH5 2NH
Telephone: 0845 30 88 330 Fax: 0845 30 11 013
technical@coruspanelsandprofiles.co.uk
www.coruspanelsandprofiles.co.uk

ASSOCIATE MEMBER
Huntsman Polyurethanes
Everslaan 45, B-3078 Everberg, Belgium
Telephone: +32 2 758 92 68 Fax: +32 2 758 72 68
insulation_europe@huntsman.com
www.huntsman.com