

## **Insulated Panels The Fire Safety Order (2005)**



**Advice and guidance on insulated panels for responsible persons and enforcers implementing the Regulatory Reform (Fire Safety) Order 2005**

# Introduction and foreword

## EPIC Guide to Fire Risk Assessment of Insulated Panels under the RRFSO

The EPIC Guide complements and significantly extends the general guidance notes that have been prepared by the Department of Communities and Local Government (DCLG) for 11 identified construction sectors(1).

The DCLG guides briefly identify 'insulated core panels' as a potential source of fuel. This EPIC Guide looks at the uses of Insulated Panels throughout construction according to their application and gives guidance on their likely performance in fire, based on extensive research into actual fires and large scale laboratory tests. This information has been prepared for the designated 'responsible person' so that a fully reasoned fire risk assessment can be made for the premises concerned.

### Regulatory Reform (Fire Safety) Order 2005 – Effective October 2006

The Regulatory Reform (Fire Safety) Order 2005 was approved by Parliament on 7 June 2005. The Order makes a number of changes as part of the review to reduce death, injury and damage caused by fire. It applies to England and Wales. Northern Ireland and Scotland have their own laws.

The main effect of the Order is to place greater emphasis on fire prevention in non-domestic premises. Fire certificates will be abolished and the responsibility for compliance with the Fire Safety Order will rest with the 'Responsible Person'. The 'responsible person' is generally the person/people in control of the premises or in a workplace, the employer and any other person who might have control of the premises, e.g. the occupier or owner.

The 'responsible person' must carry out a **'fire risk assessment'**, which shall focus on the safety in case of fire of all 'relevant persons'. This task may be passed to some other competent person but the 'responsible person' will still be responsible for meeting the Order.

The fire risk assessment will help the 'responsible person' to identify risks that can be removed or reduced and to decide the extent of the general precautions that should be taken to protect people against the fire risks that remain.

Responsibility for enforcement of the new rules lies with the Local Fire and Rescue Service Authority who will carry out regular inspections, especially to premises that present most risk to the community. These inspections will be carried out within the context of the new Integrated Risk Management Planning (IRMP) agenda for the FRS.

### Insulated Panels used in construction – EPIC and the RR(FS)O

The RR(FS)O requires the 'responsible person' to identify any hazards within their premises. These include sources of ignition such as naked flames, heaters or hot processes in some commercial organisations. Also included are 'sources of fuel' and Insulated Panels have been included as one of the materials that might provide fuel for a fire or cause it to spread to another fuel source.

### Guidance for fire risk assessors

Since 1999, EPIC has been the leading provider of information on the performance of insulated panels in fire. This Guide has been prepared to assist fire risk assessors in the identification of insulated panel systems and to determine whether they need to be taken into account in the fire risk assessment.

This EPIC Guide will be of interest to:

- The designated 'responsible person'
- Competent persons undertaking the Fire Risk Assessment
- The Fire and Rescue Services
- Insurance Surveyors

<sup>(1)</sup> [www.firesafetyguides.communities.gov.uk](http://www.firesafetyguides.communities.gov.uk) contains:  
• A 'Short Guide to making your premises safe from fire' and  
• Guidance notes for 11 different construction sectors 'to tell you what you have to do to comply with fire safety law, help you to carry out a fire risk assessment and identify the general fire precautions you need to have in place'.

#### Download information from the EPIC website

This Guide to Insulated Panels and the Regulatory Reform (Fire Safety) Order together with the other EPIC Guides can be readily downloaded from the EPIC website at [www.epic.uk.com](http://www.epic.uk.com)

# Summary

## Fire safety assessment summary

Extensive fire tests and research into fire case studies carried out following some major fires in the food processing industry in the mid 1990s have produced the following conclusions:

- Insulated panels forming the roof and wall envelope of a building have not contributed significantly to the developing stage of a fire
- External claddings that are LPCB approved to LPS 1181(2) can be regarded as satisfying the original grade 2 construction rules or be classed as a non-combustible building. (Note: This does not imply that the material is non-combustible) ABI technical briefing (3)
- For all other panels expert guidance should be sought in relation to Fire Risk Assessment, especially when being used for internal applications.

## Contents

### Insulated panels

<b>Section 1</b>	<b>What is an insulated panel?</b>	<b>4</b>
<b>Section 2</b>	<b>Where are they used in buildings?</b>	<b>6</b>
<b>Section 3</b>	<b>Performance of insulated panels in fire</b>	<b>10</b>

### Fire risk assessments

<b>Section 4</b>	<b>Principal guidelines for conducting a FRA for Industrial Panels</b>	<b>14</b>
	4.1 Introduction to Fire Risk Assessment for Insulated Panels	14
	4.2 Insulated Panels used as the external envelope	14
	4.3 Insulated Panels used for internal applications	16
	4.4 Insulated Panels used as internal linings	17
	4.5 Insulated Panels used as internal compartment walls	17
<b>Section 5</b>	<b>Identifying Insulated Panels and other cladding systems</b>	<b>18</b>
	5.1 Identifying Insulated Panels for Fire Risk Assessment	18
	5.2 Identifying Insulated Panels used for the building envelope	18
	5.3 Identifying Insulated Panels and other systems – Internal	21
	5.4 Identifying the core insulating material	22
	5.5 Identification checklist	24
<b>Section 6</b>	<b>Best practices to reduce fire risks</b>	<b>25</b>

<b>References</b>	<b>26</b>
-------------------	-----------

# What is an Insulated Panel?

This section describes the ranges of metal faced insulated panels used in the construction of non-domestic buildings excluding Cold Stores.

## 1.1 Insulated panels

Insulated panels normally consist of two metal facings either side of an insulating core. The core is either bonded to the facings using an adhesive, or by autoadhesion in the case of polyurethane, polyisocyanurate and phenolic cores. There is no air gap between the core and the facings. The panels are manufactured in a factory and delivered to the construction site as a single piece unit. Panels are generally 1 m in width and are delivered to site in lengths from 1 m to 20+ m.

Insulated panels are generally regarded as non-structural although they are strong rigid units that act compositely when under load. This strength allows loads such as wind or static forces to be transmitted to the supporting structure and it is this property that distinguishes panels from boards with thin facings such as foil facings. It is important to make this distinction because the mechanical and fire properties of panels compared to boards are totally different.



External roof panel application



External wall panel application

## 1.2 Metal facings

This guide only covers panels manufactured with metal facings. The metal facings can be flat or profiled and normally have a PVC, PVDF or other paint coating for protection against weather or other environments and a thin paint finish on the alternate facing. Other coatings are used for specific applications e.g. hygienic 'food safe' coatings for use within the food industry.

Small quantities of insulated composite systems are made with other facings such as plastics, GRP and various timbers and boards. These are outside the scope of this guide.

Insulation boards with thin facings on either side e.g. aluminium foil or bituminous felts are often wrongly described as 'panels'.

Great care should be taken to check whether a wall or wall lining is a panel and not a board when conducting a fire risk assessment (see 5.3).

## 1.3 Insulating cores

Insulated panels are designed for specific applications as illustrated in Section 2 and the central insulating core can be manufactured using various insulating materials. The choice of insulation may have a direct bearing on the performance of a panel in fire and may influence the associated fire risk assessment as described in Section 4. Insulating materials used in the manufacture of panels are:

- **Polyisocyanurate PIR (LPCB certificated systems)(2).** From 2000 these certificated panels have been increasingly used to satisfy the more demanding fire test requirements for non-combustible buildings required by the Insurance Industry. From 2004 only PIR (LPCB System) certified panels have been manufactured by the UK panel industry for the external envelope and the majority of internal applications.
- **Polyurethane (PUR)** was the most commonly used core material for insulated panels until the late 1990s gradually being replaced by PIR systems (see above). Some uncertified PIR panels were manufactured prior to 2004 but volume was very low.

- **Mineral fibre (MF)** cores are used in a variety of panels for walls, ceilings and internal compartment walls
- **Polystyrene (PS)** has been used as a core material for over 30 years mainly for panels used internally and for Cold Store panels
- **Phenolic (PF)** cores have been used on selective projects for internal walls and ceilings.

#### 1.4 Other features of insulated panels

Two other features of insulated panels have an influence on fire performance and fire risk assessment. These are:

- the manner in which panels are joined to adjacent panels and
- the way panels are secured to the building framework or supported in other ways.

##### Panel-to-panel joints

Complex joints such as those used for the external envelope are fully engineered joints that are designed to be weathertight and to prevent air leakage. Their robust interlocking nature combined with secure fixing to the building framework simultaneously gives better protection of the core from direct flame attack.

For internal panels, which do not have to withstand wind forces and driven rain, a more simple tongue and groove arrangement is used that also aids the demountability and relocation of the panels. These internal panel systems are mainly used in a freestanding form to create an environmentally controlled internal space.

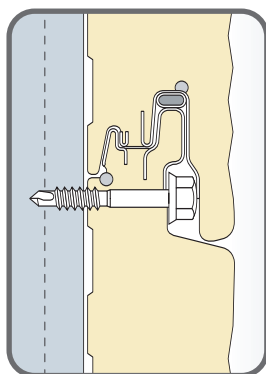

External: Typical engineered joint

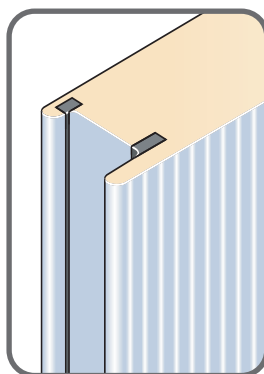

Internal: Simpler typical T&G Joint



Internal panel

##### Fixing and securement

External envelope panels, compartment wall and some lining panels are securely fixed through the facings to the structural framework of the building. **This means that in the developing stages of a fire there is no collapse exposing a combustible core due to the delamination of the facings as a result of exposure to high temperatures. (Section 3)**

Panels used internally are generally designed to be freestanding and often interlocking without fixings to a supporting structure. Ceiling panels are often supported on the wall panels and may have the additional support of hangar systems connected to the external face of the panel or to a grid framework into which the panel is placed. As the fire develops and the temperature rises, the unrestrained facings buckle with the result that the core can become increasingly exposed. (See 4.3 Fire risk assessment)

PIR (LPCB certificated systems) from 2004 and some IACSC system designs (4) from 1999 are required to have an approved structural support to restrict early collapse and exposure of the core material.

#### 1.5 Alternative names

**Insulated Panel** is now the generally accepted terminology for the panels covered in this Guide. Other terms used to describe insulated panels are '**Composite**' and '**Sandwich**'. 'Composite' is used throughout construction to refer to any combination of materials that may be classed as a 'panel' or might also be assembled on site and therefore not a true panel. The other commonly used term was 'Sandwich' panel, especially in the food processing industry. It is still a terminology used in the rest of Europe but has been replaced in the UK by 'Insulated Panel' in recent years.

# 2 Insulated Panels in buildings External

**Insulated panels can be divided into two main groups:**

- Panels designed for the external roofs and walls of buildings
- Panels designed for use internally (see 2.3)

The 2005 Regulatory Reform (Fire Safety) Order states that insulated panels used in buildings should be assessed as a possible 'source of fuel' when undertaking a fire risk assessment.

## 2.1 External roofs and walls

Insulated panels have over the past 15 years become the preferred choice for the external metal cladding of a wide range of buildings across virtually every construction sector. 10 million m<sup>2</sup> per year are installed and many buildings in each sector will have insulated panels for the roof and/or walls.

Since their introduction in the 1970s, insulated panels have been predominantly used in:

- Factories and industrial premises
- Warehouses and distribution
- Workshops and transport depots
- Retail: out-of-town stores; and distribution

From the 1990s insulated panels have been increasingly used in the following areas:

- Offices, particularly low/medium storey height
- Leisure including stadia, sports halls, cinemas
- Education – schools, colleges and universities
- Hotels, apartments and student accommodation
- Health – smaller hospitals; hospital extensions; clinics
- Transport buildings – airports, bus stations, motorway services



Industrial



Education



Office



Retail

## 2.2 Which panels are used on the external envelope?

Table I provides a useful summary of the types of panels and the core insulants that can be found in the various external applications.

There are few hard and fast rules as many of panels can be specified for a variety of applications. Guidelines and hints on how to identify the different types of panels, or even whether it is a panel, are given in Section 5.

**Table I External building envelope**

Summary table – Use of the various types of Insulated Panels [IPs] by Construction Sector.

Sector	Roof			External wall				
	PIR (LPCB certified systems)	PUR core pre 2004	Can be confused with:	PIR (LPCB certified systems)	PUR core pre 2004	MF core	PS core	Can be confused with:
<b>Factories and warehouses and retail distribution</b>	All IPs	All IPs	Site assembled systems (see 5.2)	Most IPs	Most IPs	<10% of IPs	Rare in IPs	Site assembled systems (see 5.2)
<b>Offices</b>	All IPs	All IPs	Site assembled systems (see 5.2)	Majority of IPs	Majority of IPs	20% of IPs	Occasionally in infill panel units (see below)	
<b>Retail – especially large out-of-town</b>	All IPs	All IPs	Site assembled systems (see 5.2)	Most IPs	Most IPs	<10% of IPs	Rare in IPs	Site assembled systems (see 5.2)
<b>Leisure – stadia, sports halls and cinema</b>	All IPs	All IPs	Site assembled systems (see 5.2)	All 3 core materials used			Occasionally in infill panel units (see below)	Site assembled systems (see 5.2)
<b>Education, Health, Hotels, Apartments</b>	All IPs	All IPs	Site assembled systems (see 5.2)	Most IPs	Most IPs	<10% of IPs	Occasionally in infill panel units (see below)	
<b>Transport – depots, hangars workshops, etc</b>	All IPs	All IPs	Site assembled systems (see 5.2)	Most IPs	Most IPs	<10% of IPs	Rare in IPs	Site assembled systems (see 5.2)
<b>Transport – transit buildings</b>	All IPs	All IPs	Site assembled systems (see 5.2)	All 3 core materials used			Rare in IPs	Site assembled systems (see 5.2)

### Guidance notes to accompany Table I

**Roofs.** This is probably the most straightforward area as all the roof panels used in the UK have a PIR or PUR core. The main consideration is to confirm that it is an Insulated Panel and not a site-assembled or ‘built-up-system’ roof. Guidance on this is given in Section 5.

**Walls.** Again the first step is to confirm that the wall is an Insulated Panel and not a site-assembled system (Section 5). The majority of panels in most sectors will have a PIR (LPCB certified systems) or PUR core. MF cored panels have been used to a much lesser extent in all sectors. PS cored

panels occur rarely in external wall claddings and also as infill panels.

**Infill panels.** Curtain walling systems generally use an assembly for the opaque elements comprising the external facing, insulation (slab) and an internal lining. However Curtain Walling ‘stick’ systems use factory produced infill panel units of the same width as the window module and often with the two metal skins glued to the insulating core material. Historically the three main insulants – PS, PUR and MF were used. From 2002, PIR and MF have been the predominant choice.

## 2 Insulated Panels in buildings Internal

### 2.3 Internal walls and ceilings

Insulated panels used internally account for less than 5% of the total panel usage. There are three principal applications:

- As the walls and ceilings of internal compartments to control temperature and hygiene.
- As lining panels, generally within existing buildings
- As separating, usually fire resisting walls between different sections of a building.

Panels designed for internal use are similar in design to those for external applications with the exception of the joint (Section 1.4). This is generally a simple construction designed for ease of construction and demountability to enable changes in configuration and layout to be made retrospectively.



Internal walls



Internal – environmental room

### 2.4 Which panels are used internally?

Table 2 provides a useful summary of the types of panels and core insulations that can be found in the various internal applications. The most frequent use of panels has been in food processing; controlled assembly areas; and some factories, warehouses and retail distribution.

There are few hard and fast rules as all the insulation types have been specified for most of these applications.

#### Guidance notes to accompany Table 2

##### **Internal compartments – box within box**

These compartments are common within the food processing industry and also in some industries where a ‘clean’ environment is required. Wall panels are generally freestanding and interlocking and are not connected to a supporting framework. Ceiling panels are generally supported by the wall panels with the addition of supporting hangers where larger spans are used.

Panels incorporating a polystyrene (PS) core dominated this type of application until the mid 1990s, when substitution by PIR and MF panels started due to concerns about fire performance. A number of fires where PS cored panels were used extensively for the box-within-box type of construction have highlighted the particular dangers that may be associated with this form of insulation and construction, particularly where the core can be exposed and contribute to the fire hazards.

##### **Lining panels**

Panels used for lining are similar in terms of core materials and joint design to the compartment panels described above. The performance in fire will in general be similar to the compartment panels.

**NOTE:** Aluminium foil faced lining boards should not be confused with metal-faced insulated panels. Foil facings offer little protection and any fire risk assessment should be carefully considered if these lining materials are used.

### Separating walls

Insulated panels are sometimes used as an alternative to the more general masonry compartment wall constructions. These panels have varying degrees of fire resistance and are fully supported on a structural frame. Core materials are predominantly MF with some PIR (LPCB certified systems). Performance in fire is similar to that of the MF and PIR (LPCB certified systems) panels used for the external envelope (see Section 3).

**Table 2 – Internal building applications**

Summary table – Use of the various types of Insulated Panels [IPs] by Construction Sector

Sector	Internal wall and ceiling			Compartment wall		Internal wall lining		
	PIR (LPCB certified systems)	MF core	PS core	PIR core	MF core	PIR (LPCB certified systems)	MF core	PS core
<b>Factories and warehouses and retail distribution</b>	Occasional use	Occasional use	See Food Factories below	Some PIR panels used for Comp. wall	Majority of panels for Comp. wall are MF panels	Occasional use		
<b>Factories – food preparation, packaging, handling etc</b>	PIR LPCB certified panels have gradually replaced PS panels from 1995	MF panels have replaced PS panels in areas around hot processes and elsewhere from 1995	PS panels used in many food factories pre 1995 reducing in recent years	As above	As above	Occasional use		
<b>Offices</b>	Few IPs used internally in this sector					—	—	—
<b>Retail – especially large out-of-town</b>	Few IPs used internally in this sector			As above	As above	—	—	—
<b>Leisure – stadia, sports halls and cinemas</b>	Few IPs used internally in this sector			As above	As above	—	—	—
<b>Education, Health, Hotels</b>	Few IPs used internally in this sector					—	—	—
<b>Transport – depots, hangars workshops, etc</b>	Few IPs used internally in this sector			As above	As above	—	—	—
<b>Transport – transit buildings; motorway services etc.</b>	Some LPC PIR	MF Panels most likely to be used	—	—	MF Panels most likely to be used	—	—	—

Note. Phenolic (PF) cored panels have also been used in small volumes as internal walls and ceilings in some food factory and cold store applications.

# 3

## Performance in fire of Insulated Panels

This section summarises the latest research and information on the fire performance of Insulated Panels for both external cladding and internal applications.

### 3.1 Introduction

Fire Safety Assessment under the Regulatory Reform (Fire Safety) Order is primarily concerned with life safety and the prevention of fire. This is different from assessing a building from the viewpoint of property protection or that of the Fire Services where the fire is likely to be fully developed rather than a developing fire. For life safety the prime focus is on the evacuation of occupants and on the safety of the fire rescue service, which is mostly related to the earlier phases of the fire.

Secondly, in a fire safety assessment, the performance of the panel should be viewed in relation to the performance of the specific building area, and should take into account the scale and fire load of the building contents and all other sources of fuel.

Therefore, full account has to be taken of the fact that the major source of heat, smoke and toxic hazard at the critical personnel evacuation phase of a fire, in buildings clad in PUR, PIR and mineral fibre panels, is created by the other materials involved in the initial fire. It is these hazards that are most likely to be critical in terms of life safety and which should be the principal element of the Fire Safety Assessment.

### 3.2 Factors affecting performance in fire of insulated panels

Insulated Panels consist of an insulating core bonded to two metal facings as described in section 1.1. The core can be made of various insulating materials, ranging from limited-combustibility to combustible and highly combustible. Insulated Panels are considered by the Regulatory Reform Fire Safety Order to be one of the potential sources of fuel and therefore have to be assessed as part of the Fire Safety Assessment.

In order to complete a Fire Safety Assessment it is essential to understand the way Insulated panels may perform in fire in its particular application.

The following have to be taken into consideration:

- The type of panel and its core insulating material
- Whether the panel is securely fixed or free-standing
- Factors that have a direct influence on the scale of the fire i.e. type and magnitude of the fire load of the contents of the building
- Other factors such as open edges or cut holes that expose the core and could influence the contribution of any combustible core material to the fire and which might affect the Fire Safety Assessment.

### 3.3 Influence of the type of panel system

The metal facings of insulated panels effectively protect the insulating core. The primary influence in the fire behaviour is temperature, the severity of the effect increasing with rising temperature, especially where the flames impinge directly on the panels. Differing fire hazards are associated with each of the common types of insulation (PIR; PUR; MF; PF and PS see 1.3) used in Insulated Panels.

External claddings with MF and PIR (LPCB certificated systems) that are LPCB approved to LPS 1181 are regarded by the Association of British Insurers as satisfying the original grade 2 construction rules or be classed as a non-combustible building. (Note: This does not imply that the material is non-combustible)

In a fire the following may occur;

- Production of smoke, less with MF, PIR (LPCB certificated systems) and PF
- Buckling and delamination of the facings but not necessarily collapse where the facings are fixed to the framework
- Charring and burning of non-melting combustible materials – PIR (LPCB certificated systems) and PUR – but not in amounts that may significantly contribute to the fire growth

- Burning, shrinking away from the steel and melting of combustible materials such as polystyrene (PS) at an earlier stage with quantities of smoke and some potential contribution to fire growth particularly where the fire impinges on the panel.

In a developing fire, the fire will generally be localised and the temperatures lower. At this stage the core of the Insulated Panels is protected by the metal facings unless the temperature causes the facing or panel to collapse, e.g. with some freestanding PS cored panels where the core is seriously affected at temperatures below 180°C.

For this reason it is important to distinguish between panels used for the external envelope that are securely fixed to the building framework and remain in place to protect the core and internal panels that are often freestanding or supported on other panels. In the case of internal panels the potential for collapse has to be considered in the Fire Safety Assessment.

With regard to fire prevention, the main consideration should be to keep any combustible core materials protected and the panels securely fixed to prevent collapse. Guidance on this point can be found in Section 5 on Fire Risk Assessments and within the DCLG Guides on RR(FS)O.

## Fire performance of external panels

### 3.4 Information from Fire Tests

Extensive large-scale fire tests on a range of insulated panels have been carried out by EPIC in conjunction with the major test laboratories. The information is available on the EPIC web site [www.epic.uk.com/fire\\_tests.jsp](http://www.epic.uk.com/fire_tests.jsp)

The tests give a clear understanding of the way insulated panels and insulated cladding systems perform during the developing stage of a fire at the most critical time associated with fire risk assessment and life safety.



“Observation & recording – The tests generate an average heat output of 510KW and a max output of 1MW sufficient to represent a fire in the later stages of development”

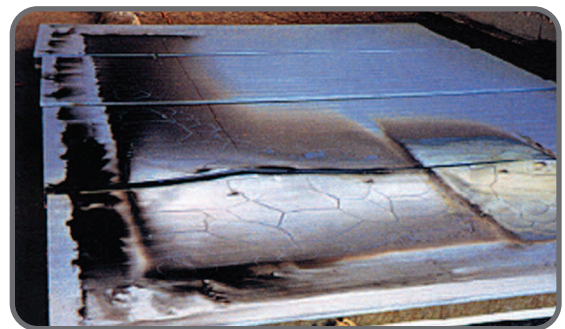

“Buckling of the internal lining occurs in all panels but joints stay essentially intact”

The results indicate that:

- Insulated Panels fixed to the building structure, in particular the roofs and external walls of buildings, remain secure without collapse even when the fire changes from a developing to developed stage
- Contribution of a combustible core to the fire i.e. as a source of fuel, is limited and gradual in the developing stage of a fire
- The contribution in terms of smoke and gases is minimal for MF, PIR and PF but slightly greater for PUR
- The contribution from PS cores is greater at an earlier stage due to the low melting point (120°C) and can result in the generation of black smoke. The bond of the facing is also compromised at an earlier stage increasing the possibility of collapse.

# 3

## Fire performance of insulated panels External

### 3.5 Information from fire case histories

EPIC and its professional fire consultants have analysed a number of fires, both internal and external, in which Insulated Panels have been affected by fire. The studies have concentrated on PUR cored panels and LPCB certified PIR panel systems, which are the most common panel types, and relate to panels that have been subject to a developed fire as distinct from the developing fire, which is more relevant to fire risk assessment.

The case histories clearly illustrate how panels perform in actual fires when they are used as the roofs and walls of buildings and are securely fixed to the building framework.

The findings from a variety of the case studies are summarised below. These have been taken from the fire services or fire consultants reports. The case histories are available for view and download on the EPIC web site:  
[www.epic.uk.com/fire\\_studies.jsp](http://www.epic.uk.com/fire_studies.jsp)

#### Example – Industrial manufacturer



- Severe fully developed fire due to large amount of plastic components
- No fire spread through the PUR insulated panels to the adjacent manufacturing units
- PUR panel partition wall prevented fire spread
- Minimal smoke damage to adjacent units with minimal loss of production

#### Example – Leisure



- Internal fire reached a fully developed stage
- The PUR panels did not contribute to fire growth or fire spread
- The insulated panels did not collapse and remained attached to the building
- Fire fighters entered the building and extinguished the fire safely

#### Example – Hospital



- Severe fire sufficient to damage intumescent coatings and distort the steel beams
- PIR (LPCB Certified) panels did not collapse or ignite
- PIR (LPCB Certified) panels did not contribute to the fire spread

### Example – School



- Intense heat in the vicinity of the fire sufficient to damage the purlins
- Panel facings remained in place despite severe buckling and delamination and exposure of the core material
- The LPCB approved PIR panels helped to prevent fire spread across the top of the compartment wall

Insulated panels used as the external roofs and walls of buildings.

In all case studies the expert's view was that the PUR insulated panels or PIR (LPCB certificated systems) did not contribute significantly to the fire development and the fire load

## 3.6 Internal applications

### History and applications

Excluding cold stores, which are outside the scope of this brochure, the primary use of insulated panels within buildings has been to create a controlled internal environment, especially in the food processing industry. Panel systems were designed to provide a hygienic solution with clean lines and were mainly freestanding with few visible fixings. Ceilings tended to be supported on the wall panels.

Similar controlled environments can be found in the electronics, pharmaceutical and similar controlled process industries.

Up to 1995 the majority of applications used polystyrene insulated panels, often in association with a hot process e.g. cookers, fryers, ovens etc. Following a number of large-scale serious fires the use of panel systems with a highly combustible polystyrene core was reviewed. From the mid 1990's the use of polystyrene panels rapidly declined in favour of PUR, PIR (LPCB certificated systems) and MF, with MF panels replacing PS in areas round hot processes.

It is a requirement of PIR (LPCB certificated systems) and some IACSC system designs (4) that they are securely fixed to a supporting framework to prevent early collapse in fire

Small quantities of phenolic (PF) panels have also been used for internal applications.

## 3.7 Potential fire concerns

Environmentally controlled spaces can present very different fire scenarios compared to open building areas.

- Areas often have low ceilings leading to a more rapid temperature rise
- With PS cored panels, quickly rising temperature leads to delamination of the facings and exposure of the core
- Core exposure leads to dense smoke and an early onset of flashover. However personnel should have had time to vacate the space.
- Some controlled environments are in the form of a maze of rooms. Panel systems look strong. With polystyrene PS panels fire can travel within the core but this is relatively slow unless there is delamination or unless large voids have been formed because of shrinking or melting.
- Occasionally PS panels have also been used to lineout exit routes. This should be checked as part of the fire risk assessment.

# 4 Fire Risk Assessments External

## 4.1 Introduction to Fire Risk Assessment for Insulated Panels

This section on Fire Risk Assessment summarises the information on Insulated Panels relevant to conducting a Fire Risk Assessment and gives guidance on the factors that should be considered by the 'responsible person'.

It also includes some of the relevant guidance notes from the DCLG Guides on RR(FS)O.

The Department of Communities and Local Government (DCLG) have prepared general guidance notes on how to comply with fire safety law and how to conduct a Fire Risk Assessment.

[www.firesafetyguides.communities.gov.uk](http://www.firesafetyguides.communities.gov.uk) contains a 'Short Guide to making your premises safe from fire' and guidance notes 'to tell you what you have to do to comply with fire safety law, help you to carry out a fire risk assessment and identify the general fire precautions you need to have in place' for 11 different construction sectors.

The assessment of Insulated Panels as a potential source of fuel under the RR(FS)O is just one of the procedures for non-domestic buildings that needs to be undertaken by the 'responsible person' as part of the Fire Risk Assessment.

Insulated Panels are not always obvious to identify and the range of core insulation materials can vary from limited combustibility to highly combustible. Sections 1-3 describe the types of Insulated Panels that are used in buildings, where they are most likely to be found (Tables 1 and 2) and most importantly how they are likely to perform in fire (Section 3). How to identify panels and the type of core insulation is set out in Section 5.

## 4.2 Insulated Panels used as the external envelope

### Summary

All external envelope panels are securely fixed to the building framework. Fire tests and studies show that collapse does not occur until the main building structure starts to be challenged by a fully developed fire.

The metal facings continue to protect the core even when the facings are buckled and the joints starting to open. Fire tests show that any contribution of the 'fuel source' is gradual even for combustible insulations and is not a significant contribution to the main fire.



External: roof and walls



External: wall

## Guidelines for Fire Risk Assessment

### 1. Contribution from the insulation core as a fuel source.

The contribution to the overall fire load is small and gradual. Some smoke will be generated from the combustible core materials but this is generally low in the developing stages of a fire, unless the panels collapse (not likely with fully fixed roof & wall panels), or if the core is exposed at an edge/opening or due to damage.

With PIR, PUR and MF cores, fire does not pass through the core from an exposed edge or opening, but can do so with a PS core. Greater amounts of smoke may be generated when the core is exposed. Part of the Fire Risk Assessment should be to identify and seal any open or damaged areas – see following Risk Reduction.

### 2. Internal Fire Load

Insulated Panels are primarily affected by temperature (see Section 3). In offices and other applications where the fire load is generally low, the panels are unlikely to be significantly affected by an internal fire and the fire risk assessment can be made accordingly.

Highly combustible materials should not be stored against panels, nor waste or rubbish to be allowed to collect against panels.

### 3. High occupancy

The DCLG Guidance regarding Insulated Panels recommends that 'the use of panels with combustible cores in areas of buildings with a high life risk, e.g. where large numbers of people are present, should be carefully considered. The fire risk assessment may need to be revised to ensure that any increased risk resulting from this type of construction is considered.

## Identification and risk reduction

Once installed it is difficult to identify the core material of a panel and its potential fire hazard. Guidance on the identification of insulated panels and cladding systems is given in Section 5.

The following best practices can help reduce risks associated with insulated panels. This advice is generally equally applicable to any insulated cladding system, not only insulated panels.

- Do not store highly combustible materials against panels or allow rubbish to collect against panels.
- Have damaged panels or sealed joints repaired immediately and make sure that jointing compounds or gaskets used around the edges of panels are in good order.
- Check where openings have been made for doors, windows, ducts and cables to ensure that these have been sealed or closed with flashings and the inner core has not been exposed.
- Check that there has been no mechanical damage e.g. by mobile equipment such as fork lift trucks. Repair any damage that has occurred.

# 4 Fire Risk Assessments Internal

## 4.3 Insulated Panels used for internal applications

### Summary

Insulated Panels used internally either to create enclosed areas or as internal linings will potentially be the closest to the initial fire. The most critical factors are the type of the core insulant and the way they are designed, mounted and secured to prevent early collapse.

PS cored panels placed around hot processes e.g. in food factories have been associated with major fires and have been susceptible to early collapse due to the loss of structure of PS even at low temperatures and the self-standing, unsecured nature of these types of panel.

**All panels surrounding or adjacent to a hot process should be thoroughly checked and the type of core material determined as part of the Fire Risk Assessment.**



Typical internal applications

## Guidelines for Fire Risk Assessment

### 1. Contribution from the insulation core as a fuel source.

As with external envelope panels the initial contribution to the overall fire load is small and gradual unless there is a collapse of the panel or facing at an early stage in the fire. Some smoke will be generated from the combustible core materials but this is generally low in the developing stages of a fire unless the panels collapse, or if the core is exposed at an edge/opening or due to damage.

With PIR, PUR and MF cores fire does not pass through the core from an exposed edge or opening. However fire can pass through a polystyrene PS core and greater amounts of smoke may be generated when the core is exposed. Part of the Fire Risk Assessment should be to identify and seal any open or damaged areas – see Risk Reduction on page 15 and section 6.

### 2. Internal Fire Load

Insulated Panels are primarily affected by temperature (see Section 3). In many factory, production and warehouse premises the internal fire load of components, goods and packaging can be high and the fuel load within an Insulated Panel will be small in comparison. Where the fire risk or fire load is high the establishment of good fire management procedures should form the foundation of the Fire Risk Assessment.

### 3. Joint design and securement

Insulated Panels used internally should be carefully checked, especially those features designed to prevent collapse. Assessments should verify the form and tightness of the joint and whether the panels are secured to a supporting framework (see section 1.4). Particular care should be taken to check that the core material is protected by secure closures or flashings, especially where Insulated Panels surround an obvious fire source e.g. a hot process such as an oven (see risk reduction procedures opposite) or where openings have been made through the panels.

In applications where the fire load is generally low, the panels are unlikely to be significantly affected by an internal fire and this can be taken into account in the risk assessment.

### Identification and risk reduction

Once installed it is difficult to identify the core material of a panel and its potential fire hazard. Guidance on the identification of insulated panels and cladding systems is given in Section 5. The following best practices can help reduce risks associated with insulated panels.

- Do not install heating appliances, such as ovens, against the panels. Operate a clear distance policy for cooking systems.
- The use of combustible panels round hot processes – ovens, fryers etc – should be carefully considered. It may be appropriate to consider their replacement with fire resistant panels
- Control ignition sources that are adjacent to, or penetrating the panels.
- Check for damage to heater tapes used to check ice build-up at doors.
- Do not use ceiling panels for storage or apply any loads to them unless the panel system has been specifically designed and installed to perform this function.
- Do not store highly combustible materials against panels or allow rubbish to collect against panels.
- Have damaged panels or sealed joints repaired immediately and make sure that jointing compounds or gaskets used around the edges of panels are in good order.
- Check where openings have been made for doors, windows, ducts and cables to ensure that these have been sealed or closed with flashings and the inner core has not been exposed.
- Check that there has been no mechanical damage e.g. by mobile equipment such as fork lift trucks. Repair any damage that has occurred.

### 4.4 Insulated Panels used as internal linings

Panels used for lining the inside of a building are similar in core materials and joint design to the internal panels described above.

The performance in fire will in general be similar to panels used for internal separation (see 4.3). The following additional comments apply:

- In general lining panels will be fixed to some form of framework. Not all panel systems will be secured through the exposed internal facing and therefore these panels may be more likely to buckle and lose structural strength than external panels.
- In older buildings there may be cavities behind the panels where they are used to create an internal envelope. It is possible for a fire to spread behind the panels, unnoticed and unchecked by fire barriers.

**NOTE:** Aluminium foil faced lining boards should not be confused with metal-faced insulated panels. Foil facings offer little protection and any fire risk assessment should be carefully considered if these lining material are used.

### 4.5 Insulated Panels used as internal compartment walls

Where Insulated Panels are used as a fire resistant compartment or separating wall between areas within a building, the type of core and its fire resistance rating must be checked as part of the Fire Risk Assessment.

In addition the materials or system to which the separating wall abuts – wall roof or ceiling – should have the same fire resistance rating or better than the separation wall.

The joints between the separating wall and roof, wall or ceiling elements should be capable of stopping the transmission of flame, smoke and gases and any insulation materials and sealants used should be proven to the same fire resistance rating.

**Best practices to reduce fire risks associated with Insulated Panels is summarised in table 5 which can be found on page 25.**

# 5 Identifying Insulated Panels External

## 5.1 Identifying Insulated Panels for Fire Risk Assessment

Sections 2 and 3 of this Guide illustrate how panels are used in modern constructions and indicate how they are likely to perform in fire.

In order to carry out a Fire Risk Assessment and assess whether the Insulated Panel will contribute as a source of fuel it is necessary to determine three points:

- Is the construction an Insulated Panel
- What is the insulating core material
- How are the panels fixed

There are a number of potential sources of information available to assist in the identification of the cladding system and to confirm that the construction is an Insulated Panels and not a site assembled or built-on-site system.

### CDM health and safety file

For buildings built after 1995/6 the primary source of information should be the Construction Design and Management [CDM] Health and Safety File. This file should contain the as-built specification of the materials used in the building and copies of the manufacturer's literature. It will also identify whether the panel is LPCB/FM certificated. Copies of the file should be retained by the Building Owner. Copies will also be retained for some time by the Architect and the Planning Supervisor.

In cases where the building was built before the introduction of CDM or the H&S File is not available, other sources of information are:

- The architect/designer, or Design and Build company
- The construction company
- The cladding contractor for the project
- The building owner or property company's records.

## 5.2 Identifying Insulated Panels – the building envelope

### Site assembled cladding systems

Metal clad industrial and commercial buildings built prior to the mid 1980's were mainly constructed using a site assembled cladding systems for the external roofs and walls. These consisted of:

- a. A profiled metal external weather sheet
- b. A glass fibre quilt type insulation
- c. A lining system usually comprising plasterboard in 'T'-bars, or occasionally a flat faced metal lining sheet

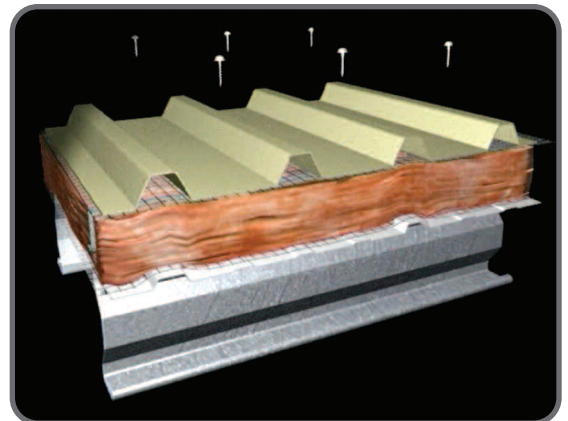

### Introduction of Insulated Panels from 1980

Insulated Panels, delivered to site as a single piece component and incorporating a polyurethane [PUR] insulating core, started to be used in greater quantities from 1980, accounting for 10% of the market by 1990, 40% by the end of the 1990's and over 60% by 2006.

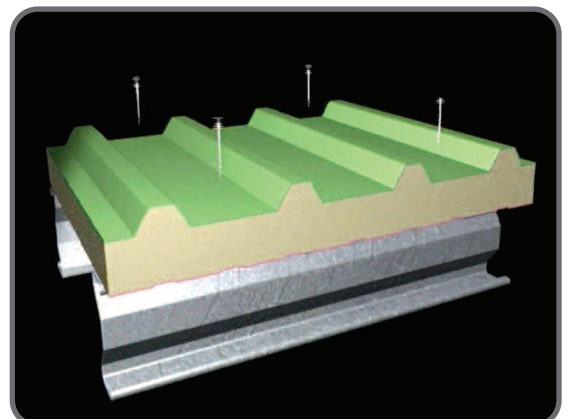

## Is it a panel or a site assembled system?

The shape of the external profile can provide a valuable clue to the type of cladding system.

### Deep profiles

If the external facing is a regular deep profile typically 35-40 mm, it is most likely to be a site assembled system with a glass or mineral fibre quilt insulation. A hollow sound when tapping the crown of the profile should indicate this type of system. This type of system is found on roofs, and walls of older buildings.

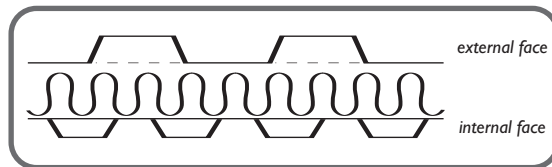

Site assembled system profile

If the external face has an irregular profile with longer distance between crowns then the cladding is most likely to be an Insulated Panel. These panels are found on both roofs and walls of buildings.

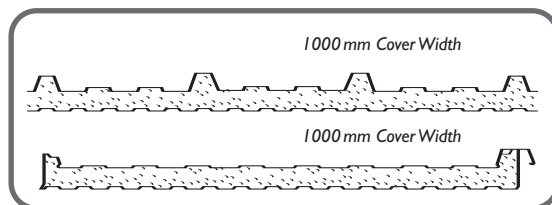

Insulated panel profile

### Standing seam profiles

Roof systems where the external sheet has a narrow raised rolled seam at the joints is most likely to be a site assembled 'standing seam system with MF quilt insulation. However a small amount of insulated panels with standing seam joints have been used since 1998. To confirm if it is a panel, check for firmness and solidity of the roof system and also whether the internal facing has a micro-box profile.

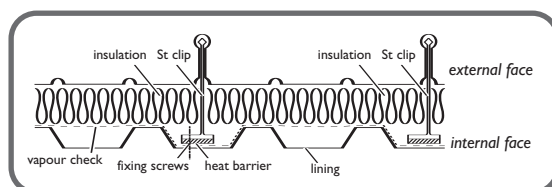

Typical standing seam roofing built-up system with quilt insulation

### Roofs without easy access

Where roof access is not easily possible to identify the cladding system, inspecting the internal lining can provide valuable clues. The internal facing of an insulated panel will be relatively flat with a mini-box profile. The corresponding metal liner sheet for site-assembled systems will have a profiled liner approximately 20 mm or slightly deeper.

### Micro-rib profiles

Wall claddings that run vertically from ground or short wall to eaves and which have a micro-rib or flat profile will be an Insulated Panel System. Similarly cladding running in a horizontal format between columns will be Insulated Panels. (See also cassette panels below).

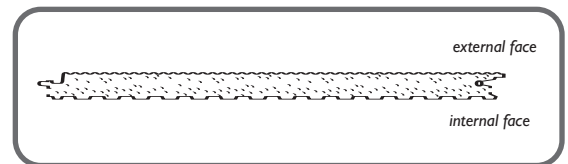

### Cassette systems

Wall cladding systems that are a multiplicity of small panels i.e. 2.5 x 1.2 m tightly supported in a support frame or grid are likely to be panels. However the type of insulation should be carefully checked as some panel types were manufactured with polystyrene cores.

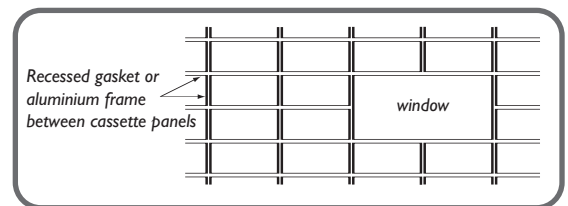

Typical cassette panel arrangements often with polystyrene insulation.

### Curves

Curved roofs where the radius is quite noticeable are most likely to be constructed using the standing seam system. Curved roofs with a very shallow curve with or without a standing seam joint system could be constructed from Insulated Panels. The end of the panel/cladding at the eaves or gutter should be checked to confirm the type of system that has been used.

A general summary guide is shown in Diagrams 1 and 2.

# 5 Identifying Insulated Panels External

## Profile identification summary

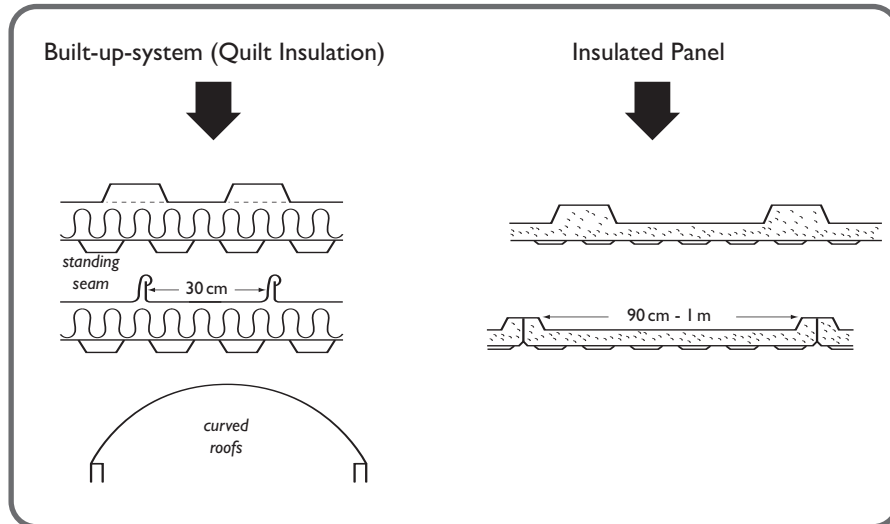

Diagram 1. Roofs – identification by profile shape

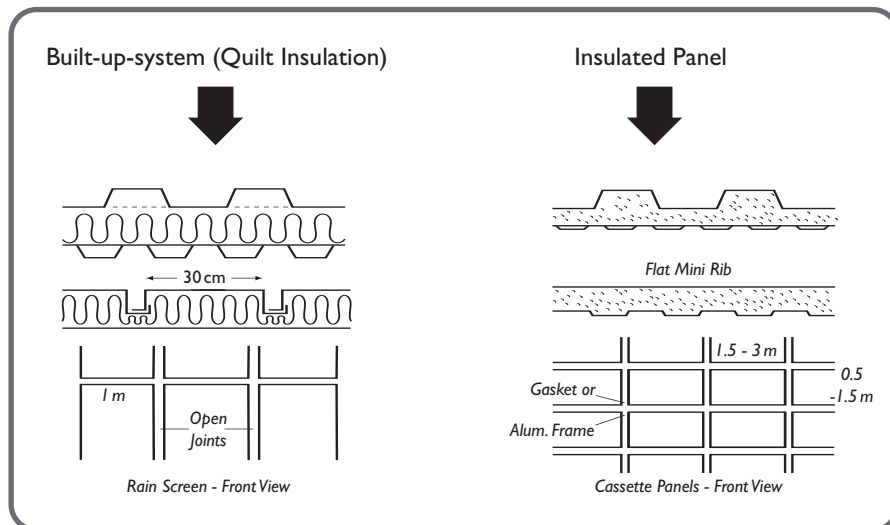

Diagram 2. Walls – identification by profile shape

### Fixings

The majority of Insulated Panel systems and all site assembled systems use through fixings that secure both external and internal facings to the building structure. This prevents collapse of the panels in fire and allows the metal facings to remain in place and provide a degree of protection to the insulating core.

Some external wall Insulated Panel systems are designed with an engineered interlocking joint that combines hidden (non-visible) fixings and a separate interlocking fixing plate. These systems are also effective in retaining the facings during the developing stages of a fire.

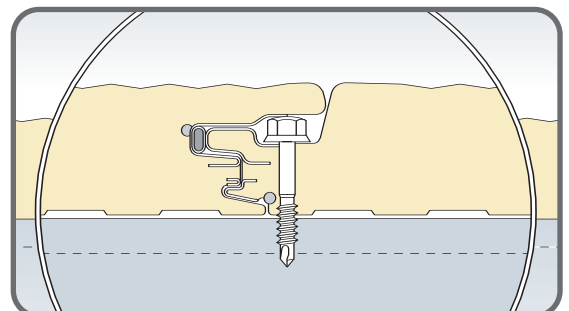

Illustration of a secret fix joint

## Identifying Insulated Panels Internal

### 5.3 Identifying Insulated Panels and other systems – Internal

#### Internal walls and ceilings

Insulated panels are frequently used to create environmentally enclosed spaces within buildings. These are illustrated in section 2.3. The panels have micro-box or flat facings and will be of varying thickness according to the temperature i.e. ambient activities, chilled storage etc.

The type of panel and the insulating core can only be determined by inspection at an end or cut section – see Section 5.4.

#### Metal liner sheets or tray systems

Where metal linings or claddings are used, for most constructions tapping the liner will determine if it is a solid insulated panel or a hollow built-up system. It should be noted that some thick structural linings have been used in sports halls etc where the incidence of damage is high. These liner sheets are generally mounted horizontally and may not exhibit a hollow sound.

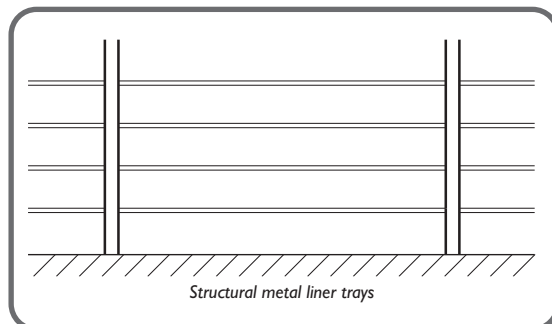

Structural metal liner trays.

#### Other internal wall lining systems

Over the years a variety of wall lining systems that should not be confused with panels have been used, particularly in industrial and warehouse applications.

Most 15-20+ year old buildings have non metallic linings. These are typically made from plasterboard sheets in 'T-bars' as part of a built-on-site system.

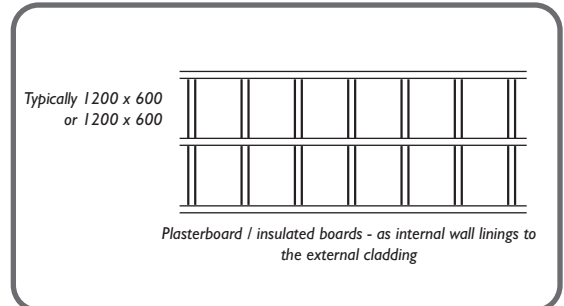

Plasterboard/insulated boards as internal wall linings to the external cladding.

Alternatively many older buildings have been retrofitted with faced insulation boards where the internal joint has been sealed with a tape. The facing of some boards is made of aluminium foil.

In fire the thin aluminium foil facings and similar do not offer protection from fire and the T-bars do not retain the boards. Fire can therefore break through behind the wall lining and involve the insulation or spread unseen in the cavity behind the system. If there is a probability of this happening then this should be taken into account in the fire risk assessment.

Two foil-faced board systems have LPCB certification and an improved fire performance. These boards can be identified by checking for glass fibres that are visible within the PIR core.

#### Lined-out buildings

Some buildings are constructed of a basic shell with roof and wall cladding that acts as a weather sheet and which has been lined out with panels. In most of the buildings the panel core will be polystyrene. As with lining boards above, this form of construction creates a potential hidden chimney behind the wall lining allowing an internal fire to spread unnoticed.

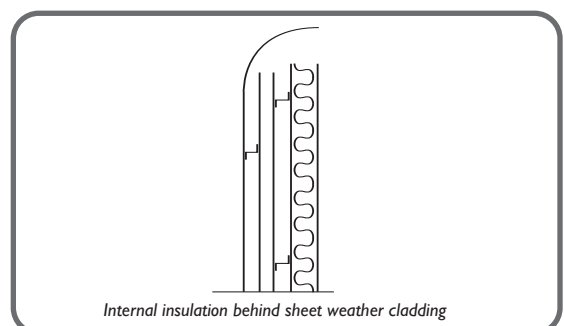

Internal insulation behind sheet weather cladding

# 5 Identifying Insulated Panels

## Core insulation

### 5.4 Fire risk assessments

The earlier sections of this Guide have emphasised the importance of determining the type of core insulation as part of the Fire Safety Assessment.

The first stage should be to check whether the type of core material is recorded in the records (5.1). If no record is available a visual check is the only alternative.

There are some other helpful guidelines. The use and distribution of various types of Insulated Panels and their respective core insulant is described in Tables 1 and 2. PIR/PUR core insulation has exclusively been used for insulated roof panels. The only task therefore is to determine that the roof is an Insulated Panel system and not a site assembled system.

PIR/PUR is the main core material used for wall panels. MW is used for external wall panels and very occasionally PS has been used for some infill panels. In internal applications all core materials have been used. It is therefore necessary to visually check the core to identify the type of insulation used in wall panels.

#### Checking for LPC/FM certificated panels with PIR insulation

- Check CDM and other records (see section 5.1)
- Check the longitudinal edge of the panels, if accessible – some manufacturers use a printed identification tape
- Check for a UV identification code printed on the internal face by some manufacturers

#### Checking the core insulation

It is sometimes possible to find a small exposed area at the top or end of a panel or wall section. The core can also be exposed by unscrewing/ removing a short section of flashing at a corner, reveal, or edge detail. It is not recommended to cut holes in the facing of a panel.

### Identifying the type of insulation

#### Mineral fibre (MF) and glass fibre

Site assembled systems use a quilt form of this insulation. It is of low density, spongy and very similar to loft insulation.

In Insulated Panels a high density form of MF with the fibres running perpendicular to the panel facings is used. This core material is quite distinctive and obviously fibrous in nature.

#### Polystyrene (PS)

Well known and recognisable from its use as a packaging material.

#### Polyurethane (PUR) and polyisocyanurate (PIR)

If not MF or PS the core is most likely to be PUR or PIR, which is used in the majority of Insulated Panels.

It is not possible to visually distinguish between PUR and PIR<sup>(2)</sup>. The majority of panels installed before 2000 will be PUR cored.

#### PIR (LPCB certificated systems)

Some PIR (LPCB certificated panel systems) were manufactured before 2000. From 2000 the urethane panel manufacturers steadily changed production and from 2005 all UK produced external panels and most internal panels were manufactured as PIR (LPCB certificated systems). External claddings that are LPCB approved to LPS 1181 can be regarded as satisfying the original grade 2 construction rules or be classed as a non-combustible building. (Note: This does not imply that the material is non-combustible)

#### Phenolic (PF)

It is difficult to distinguish between PF, PUR and PIR. PF is denser and more friable but the only sure differentiation is by laboratory test<sup>(2)</sup>.

#### NOTE 1.

An indication of the fire performance of PUR and LPC PIR panels is given in Section 3. PIR (LPCB certificated systems) (2) has an improved performance but for external applications of panel it should not normally be necessary to distinguish the type of rigid urethane for Fire Risk Assessment. Similarly for internal applications with low fire load or low fire risk it should not be necessary to determine the exact type of urethane. The need for precise identification will be as required by the Fire Risk Assessment.

#### NOTE 2.

Panel systems certificated by Factory Mutual (FM). A number of projects have been built using PIR panels tested and certificated by FM. These panel systems are very similar in formulation and design to the PIR (LPCB certificated systems) panels and have a similar fire performance but with different fixing requirements. These panels have primarily been used on buildings constructed for American Corporations where American Insurance is involved. FM panel systems should be identifiable from the project records.

<sup>(2)</sup> It is possible using laboratory tests to identify whether the core is likely to PIR or PUR (few panels manufactured before 2000 will be PIR). Panels with Loss Prevention Council LPCB or Factory Mutual FM certification will have a PIR core. Similar tests can identify phenolic (PF) core material.

## 5.5 Identification checklist

Tables 3 and 4 provide a useful checklist to support a Fire Risk Assessment. The checklists can be separately downloaded from the EPIC website – [www.epic.uk.com](http://www.epic.uk.com)

**Table 3**

External building envelope	Type of cladding system				Type of core insulation				
	Insulated panel	BU system	Other system	CW stick system	PIR (LPCB) certificated	PUR	MF	PS	PF
<b>Roof</b>									
<b>Wall</b>									

**Key**

**Cladding system** BU System = Built-up or site assembled system (see Section 5):  
 CW stick system = Curtain walling panel system (see 2.2)  
 Other system = Slates/tiles; asbestos roof; flat roof; any other non-metallic roof.

**Insulation** Types described in section 1.3. PIR = polyisocyanurate  
 PUR = polyurethane  
 MF = mineral fibre  
 PS = polystyrene  
 PF = phenolic

**Colour codes**  Care required to assess whether affects risk assessment as potential fuel contributor.

**Table 4**

Internal applications	Type of cladding system				Type of core insulation				
	Insulated panel	Other system	Foil lining systems	Other lining system	PIR (LPCB) certificated	PUR	MF	PS	PF
<b>Box within box</b> (Section 2.3) Walls and ceiling									
<b>Environmental compartments</b> (Section 2.3) Walls and ceilings									
<b>Internal linings to building</b> Walls and ceilings									
<b>Fire resisting compartment walls separating different parts of buildings</b>									

**Key**

**Insulation** Types described in section 1.3. PIR = polyisocyanurate  
 PUR = polyurethane  
 MF = mineral fibre  
 PS = polystyrene  
 PF = phenolic

**Colour codes**  Care required to assess whether affects risk assessment as potential fuel contributor.  
 Potential fuel contributor. Specialist assistance recommended when making Fire Risk Assessment.

# 6

## Best practices to reduce fire risks

Sections 4.1 to 4.5 illustrate that for the majority of applications the probability of Insulated Panels providing a fuel contribution that might affect life safety is low.

DCLG in their guidance documents (1) and the Insurance Companies have identified best practices and good fire management procedures to assist companies minimise any risks associated with Insulated Panels. It should be noted that this advice is applicable to all metal cladding systems and not just to panels

Table 5 lists the principal points that should be checked and the actions to be carried out. These issues should be part of standard regular Fire Management Procedures and not just points that should be checked during the Annual Fire Risk Assessment.

**Table 5. Best practices to reduce fire risks associated with some Insulated Panels.**

Best practice and fire risk reduction	Advice and actions
1. Check there is no damage to panel or sealed joints. Only use repair materials of equal or better fire performance to the panel system.	Have damaged panels or sealed joints repaired immediately and make sure that jointing compounds or gaskets used around the edges of panels are in good order.
2. Check that there is no exposed core material.	Check where openings have been made for doors, windows, ducts and cables to ensure that these have been sealed or closed with flashings and the inner core is not exposed.
3. Check for mechanical damage.	Check that there has been no mechanical damage and repair any that has occurred e.g. by mobile equipment such as fork lift trucks.
4. Check the type of panels and core materials used round hot processes.	The use of combustible panels round hot processes – ovens, fryers etc. – should be carefully considered. It may be appropriate to consider their replacement with fire resisting panels.
5. Check the distance from hot processes.	Do not install heating appliances, such as ovens, against the panels. Operate a clear distance policy for cooking systems.
6. Check potential ignition sources.	Control ignition sources that are adjacent to, or penetrating the panels.
7. Check heater tapes.	Check for damage to heater tapes used to check ice build-up at doors.
8. Check there is no waste, rubbish or flammable materials e.g. flammable packaging stored adjacent to panels.	Fires are often started accidentally or deliberately in skips and rubbish containers located adjacent to panels that are the external wall of the building or to flammable materials stored against panels internally
9. Check that ceiling panels are not being used to store materials or being used as access.	Do not use ceiling panels for storage or apply any loads to them unless the panel system has been specifically designed and installed to perform this function.

# References

1. DCLG documents and guides on the Regulatory Reform (Fire Safety) Order can be obtained from [www.firesafetyguides.communities.gov.uk](http://www.firesafetyguides.communities.gov.uk)
2. PIR (LPCB certificated systems) and FM certificated panels are Insulated Panels that have been tested to the specific fire test requirements of the Loss Prevention Council or Factory Mutual Insurance. These requirements are well in excess of the requirements of the UK Regulations in Approved Document B. Further details are given on the EPIC website – [www.epic.uk.com](http://www.epic.uk.com)
3. ABI technical briefing on the fire performance of sandwich panel systems. [www.abi.org.uk/bookshop/default.asp#Fire\\_and\\_Arson\\_Prevention](http://www.abi.org.uk/bookshop/default.asp#Fire_and_Arson_Prevention)
4. Design, construction, specification and fire management of insulated envelopes for temperature controlled environments. International Association of Cold Storage Contractors (1999).

## Additional information

### Fire tests.

Information on extensive large-scale fire tests carried out on behalf of EPIC by Warrington Fire Research and ARUP Fire Consultants is available on the EPIC web site:

[www.epic.uk.com/fire\\_tests.jsp](http://www.epic.uk.com/fire_tests.jsp)

### Case Histories.

A series of fire case histories illustrating the performance of insulated panels in actual fires with commentary by Tenos Ltd, Fire Consultants are available for view and download on the EPIC web site: [www.epic.uk.com/fire\\_studies.jsp](http://www.epic.uk.com/fire_studies.jsp)



EPIC was set up in 1991 to promote quality roofing and cladding systems through the use of factory-engineered panels. Insulated panels maximise thermal efficiency whilst reducing the risk and effects of condensation and significant energy loss through air leakage.

The new building regulations and today's cost competitive and quality conscious environment require that industrial and commercial buildings are high performance designs working with maximum efficiency and minimum running costs. Rigid urethane insulated panels allow designers to achieve these goals with confidence and minimum risk.

**Contact EPIC** 29 High Street, Ewell, Surrey KT17 1SB Telephone: 020 8786 3619 Fax: 020 8786 8887 [www.epic.uk.com](http://www.epic.uk.com)

#### Download information from the EPIC website

This guide on Insulated Panels and the Regulatory Reform (Fire Safety) Order has been designed to assist professionals and 'the Responsible Person' when undertaking a Fire Risk Assessment under the above Order. The guidance document and the check list can be separately downloaded from the website at [www.epic.uk.com](http://www.epic.uk.com)

#### EPIC have also published a series of other Guides including:

- Fire safety, Specification and Installation of Insulated Panels
  - Amendments to the Building Regulations Part L2 (England and Wales) and Part J (Scotland) – Guide to requirements and compliance
- These guides are available in hard copy form and through the website.

#### Information on CD Rom

EPIC has produced two CD Roms that provide comprehensive information on the design and performance of Insulated Panels used as the roofs and walls of buildings. These can be ordered directly from EPIC or through the EPIC website.

- Guide to the performance of insulated cladding systems: The CD covers cladding problems and solutions: thermal design and performance: and design detailing.
- Insulated cladding systems – performance in fire: The CD provides essential data about the fire performance of external cladding panels based on extensive research programmes.

#### THE EPIC MEMBERS ARE:

##### Corus Panels and Profiles

Llandybie, Ammanford,  
Carmarthenshire SA18 3JG  
Telephone: 01269 850691 Fax: 01269 851081  
[technical@coruspanelsandprofiles.co.uk](mailto:technical@coruspanelsandprofiles.co.uk)  
[www.coruspanelsandprofiles.co.uk](http://www.coruspanelsandprofiles.co.uk)

##### A. Steadman & Son Limited

Warnell, Welton,  
Carlisle CA5 7HH  
Telephone: 0169 74 78277 Fax: 0169 74 78530  
[info@steadmans.co.uk](mailto:info@steadmans.co.uk)  
[www.steadmans.co.uk](http://www.steadmans.co.uk)

##### Kingspan (Insulated Panels) Limited

Greenfield Business Park No 2, Greenfield,  
Holywell, Flintshire CH8 7HU  
Telephone: 01352 716100 Fax: 01352 710161  
[info@kingspanpanels.com](mailto:info@kingspanpanels.com)  
[www.kingspanpanels.com](http://www.kingspanpanels.com)

##### Ward Insulated Panels Limited

Sherburn, Malton,  
North Yorkshire YO17 8PQ  
Telephone: 01944 710591 Fax: 01944 710555  
[wbc@wards.co.uk](mailto:wbc@wards.co.uk)  
[www.wards.co.uk](http://www.wards.co.uk)

##### Kingspan Controlled Environments Limited

Hangar 1A, Wrights Lane,  
Burtonwood, Cheshire WA5 4DB  
Telephone: 01925 711157 Fax: 01925 71115845  
[info@kingspanCE.com](mailto:info@kingspanCE.com)  
[www.kingspanCE.com](http://www.kingspanCE.com)

##### ASSOCIATE MEMBER

##### Huntsman Polyurethanes

Everslaan 45, B-3078 Everberg,  
Belgium  
Telephone: +32 2 758 9874 Fax: +32 2 758 9018  
[www.huntsman.com](http://www.huntsman.com)